

# 834

## PRODUCT BULLETIN

### Microwave Solids Flow Indicator Product & Installation Bulletin



#### Model SFI

Monitor's **SFI** Microwave Solids Flow Indicator provides non-contact detection of the flow of powders or granular solids moving through pneumatic lines, feeders, or gravity chutes via low energy microwaves. Reflected energy is converted into an analog output which is "relative" to the magnitude of the flow/no-flow condition that exists. See the "Applications" section of this bulletin for further explanation.

Microwave technology is used because microwaves are virtually unaffected by heat, humidity, ambient light, pressure, vacuum, high or low temperatures, or dust, thus providing maximum effectiveness in industrial environments. This non-intrusive sensor contains no moving parts or probes that can wear out or break off in the material flow, thus ensuring process integrity and maintenance-free operation.

- ▼ Indicates Relative Amount of Flow/No-Flow Condition in Chutes
- ▼ Analog Output
- ▼ Low-Voltage Operation
- ▼ Non-Contact/Non-Intrusive
- ▼ Excellent Sensitivity
- ▼ Designed for Easy Set-up and Calibration
- ▼ FM/CSA Dust Ignition-Proof Approval
- ▼ No Maintenance
- ▼ Best Value for Flow Indication

#### PRINCIPLE OF OPERATION

The **SFI** is a microwave transceiver (combination transmitter/receiver) encased in a cast aluminum housing with a screw-on cover. A process seal (Teflon® or Ryton®) acts as a transparent window through which the microwave energy is transmitted and the reflected return signal is received. The transceiver module generates and transmits a microwave signal into the area where material flow is to be monitored. The reflected microwave signal shifts in accordance with the Doppler Effect phenomena. The magnitude of the Doppler-shifted energy is relative to the magnitude of the flow/no-flow condition when material velocity is constant.



Monitor Technologies LLC

44W320 Keslinger Rd. ▼ P.O. Box 8048 ▼ Elburn, IL 60119-8048 ▼ 630-365-9403 ▼ 800-766-6486 ▼ Fax: 630-365-5646 ▼ <http://www.monitortech.com>

## APPLICATIONS

The **SFI** provides detection of flow in solid material handling applications including gravity chutes and pneumatic pipelines. Typical industries for the **SFI** include chemicals, feed, plastics, utilities, cement and food processing. By furnishing an analog output, the **SFI** provides more information for the user than a “on-off” flow detector.

The **SFI** can be used to indicate the relative amount of flowing material. The accuracy of this indication will vary from application to application and will typically provide a very rough estimate of mass flow.

### Factors which influence the accuracy of the SFI:

- ▼ Particle Size Distribution
- ▼ Dielectric Constant Variation
- ▼ Moisture Content Variation
- ▼ Dispersion of Product Flow within Conveying Line
- ▼ Velocity of Product Flow
- ▼ Location of Product Flow with respect to **SFI**
- ▼ Auxiliary Equipment Movement (feeders, mechanical conveyors, etc.)
- ▼ Temperature Variation
- ▼ Type of Conveying System

### Type of Conveying System vs. Quality of Indication

*Free Falling in Gravity Chutes* – best indication

*Dilute Phase Pneumatic Lines* – can achieve good flow indication if velocity remains constant

*Sliding down Gravity Chute* – questionable

*Air Slides* – questionable

*Dense Phase Pneumatic Lines* – questionable

### TYPICAL APPLICATIONS INCLUDE:

- ▼ **Chemical Industry** - flow indication for blending, loading, discharging, etc.
- ▼ **Feed Mills** - indicate flow of ingredients and additives
- ▼ **Plastics** - blending applications for color or hardness characteristics
- ▼ **Power Industry** - measuring flow of pulverized coal to burners/boiler
- ▼ **Cement Industry** - batching, loading, off-loading
- ▼ **Food Processing** - indicate flow of ingredients and additives.

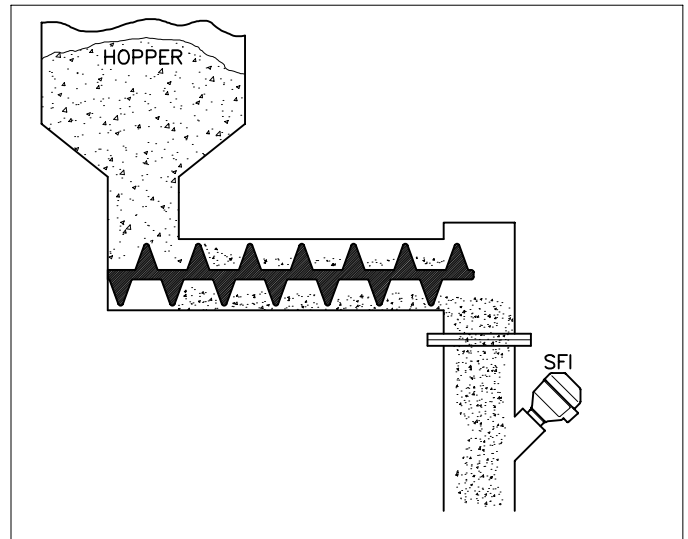

SFI provides mass flow indication to help ensure flow rate from feeders and conveyors is within acceptable range.

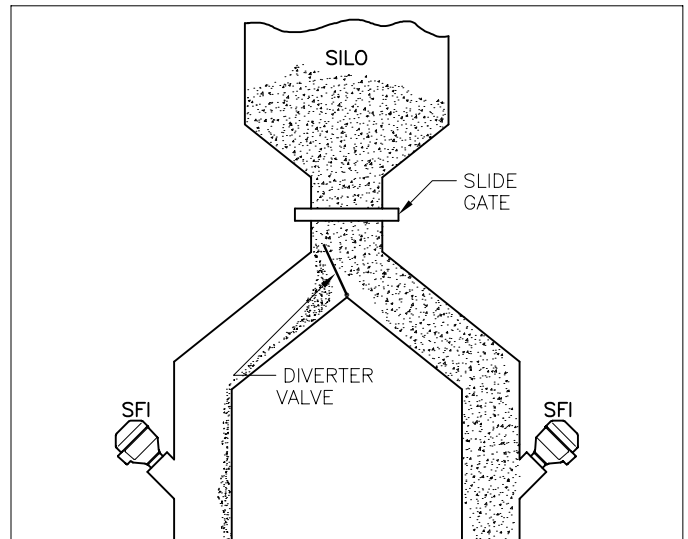

SFI signals underfeed or overfeed conditions that may result from malfunctioning process equipment such as a diverter valve.

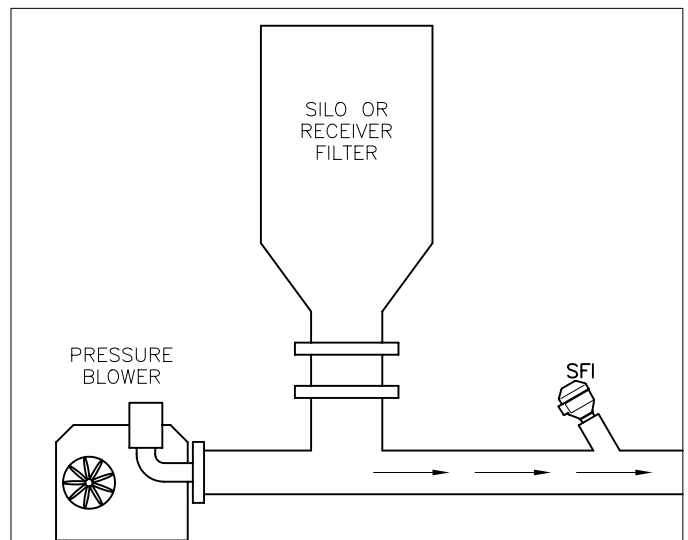

SFI indicates the estimated relative flow of pneumatically conveyed pellets, granules and powders.

## FEATURES

- ▼ **Non-Contact/Non-Intrusive** design provides long-term reliability, elimination of process contamination, and absence of intrusive probes which might wear out, break off, or inhibit material flow.
- ▼ **Rugged Housing** is rated for Class II dust-ignition proof environments and meets NEMA 4 water-tight and dust-tight classification.
- ▼ **LED Indicators** located in the sensor head provide visual indication of material activity and verification of operation.
- ▼ **Sensitivity Adjustment** allows user to switch from "HI" to "LO" depending on application parameters.
- ▼ **Zero and Span Adjustments** allow user to easily set the analog signal to the optimum for the application.
- ▼ **Built-in Averaging Adjustment** smooths out the analog signal and provides for further application customization capabilities.
- ▼ **Analog Output** provides indication relative to the magnitude of flow/no-flow condition that exists.

## ORDERING INFORMATION

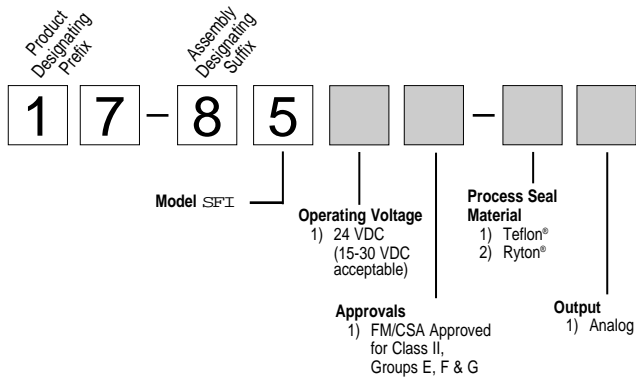

### Accessories

17-3000-7c	Locknut for securing housing in mounting coupling
17-3102-1	Saddle Coupling w/Gasket
17-3111	Half Coupling, Galvanized Steel
17-3303-1	Adapter T304 S.S., 1-1/2" NPT, Teflon® Process Seal
17-3303-3	Adapter T304 S.S., 1-1/2" NPT, Ryton® Process Seal
17-3305-1	Adapter T304 S.S., Food Grade Tri-Clamp®, Teflon® Process Seal
17-3305-3	Adapter T304 S.S., Food Grade Tri-Clamp®, Ryton® Process Seal

## MECHANICALS

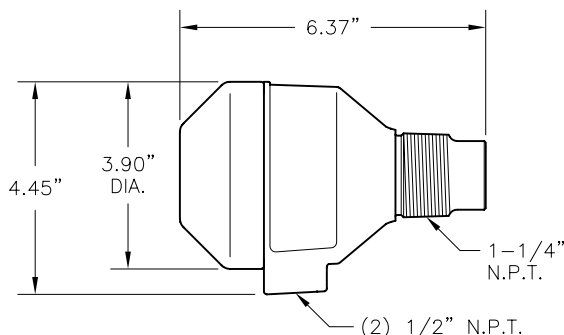

## OPTIONS

### RYTON® PROCESS SEAL

The **SFI** comes standard with a Teflon® process seal window through which the transmit/receive signal passes. A Ryton® seal is available for use in lines with high pressure or in lines carrying abrasive materials.

## ACCESSORIES

### GALVANIZED HALF-COUPLING

Monitor provides a galvanized half-coupling which can be welded to the chute or pipe for mounting the sensor head. Half Coupling: P/N 17-3111

### LOCKNUT

The optional lock nut provides flexibility in the depth of the mounting of the sensor head to ensure an internal flush mount installation. Lock Nut: P/N 17-3000-7C

### SADDLE COUPLING

The saddle coupling provides a means of mounting the **SFI** sensor head without welding a mounting coupling. The saddle coupling which includes a gasket, is suitable for round chutes, 4 to 10" in diameter, and can be easily clamped to the chute or pipeline. Saddle Coupling: P/N 17-3102-1

### STAINLESS STEEL ADAPTERS

Four different mounting adapters can be used to provide a stainless steel process contacting surface. The adapter can be of either 1-1/2" NPT or Tri-Clamp® food grade construction, and can be ordered with either Teflon® or Ryton® seals. See Ordering Information for P/Ns.



SFI with accessories.

# INSTALLATION & OPERATION

## PRE-INSTALLATION CONSIDERATIONS

Pre-installation planning is the most critical element in achieving a successful **SFI** application. The following issues all influence the effective sensitivity and quality of the flow indication. Whenever possible, the selected mounting location should be the one which maximizes the sensor's ability to see material flow.

### INSTALLATION ISSUES INFLUENCING SENSITIVITY

**1) Mounting Angle:** Whenever possible select a mounting location where mounting can be made at a 25 to 45 degree angle with respect to material flow. Angle-mounted sensors are more sensitive than those aimed perpendicular to material flow.

**2) Mounting Orientation:** Select an orientation on the pipe/chute by which the process seal will be exposed to the full motion of material flow under normal process conditions. Avoid mounting immediately after a bend, elbow or other irregular pathway. The closer the material flow is to the location of the sensor face, the better.

**3) Pipe/Chute Material:** Whenever possible select a mounting location where the pipe/chute is metallic. When microwave energy is entrapped within metal containers, internal reflections are produced therefore increasing the probability to see material motion. For non-metallic pipes such as glass, plastics and concrete, internal reflections are not as prevalent. Therefore, sensors in applications utilizing metallic pipes/chutes inherently are more sensitive than those in applications utilizing non-metallic pipes/chutes.

**Note:** Since microwave energy can propagate through non-metallic material, the sensor can be truly non-contact if directed through a non-metallic window.

**4) Pipe/Chute Diameter:** Whenever possible select a mounting location where the pipe/chute diameter is smallest. As the diameter of the pipe/chute increases, the effective sensitivity of the sensor decreases. Internal reflections are not as significant. In addition the transmitted microwave energy loses its power density as it travels through greater distances. Therefore, sensors in applications utilizing small diameter pipes/chutes inherently are more sensitive than those in applications utilizing large diameter pipes/chutes.

**5) Target Movement:** Whenever possible, select a mounting location with minimal vibration, away from feeders, conveyors and augers, so the **SFI**'s output is not falsely influenced by apparatus movement or the related vibration. Electronic signal conditioning is designed to ignore very slow moving objects, but respond to greater velocities typically associated with moving material. The sensor is capable of detecting objects moving in excess of 1.2 ft/sec.

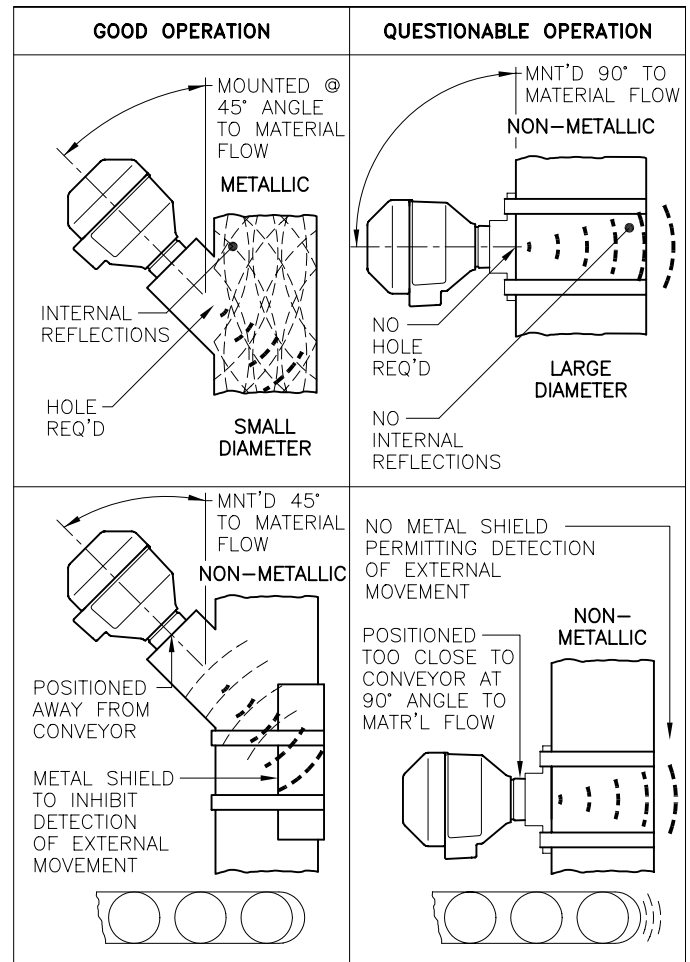

Figure 1

### MATERIAL ISSUES INFLUENCING SENSITIVITY

**1) Material Density in the Pipe/Chute:** As more product is placed in motion, the amount of disturbance which is analyzed as motion also increases. Therefore, sensors in applications which have significant material flow inherently are more sensitive than those in applications with minimal material flow.

**2) Material Dielectric Constant:** Microwave propagation is affected by the dielectric constant of the material being sensed. Typically, low dielectric or dry materials tend to absorb/pass the energy while high dielectrics or moist materials tend to reflect the energy. The **SFI** will sense material better when energy is reflected. Therefore, sensors in applications with high dielectric or moist materials (e.g. grains, feed, ores) inherently are more sensitive than those in applications with low dielectric or dry materials (e.g. plastics, soap, cement).

**3) Material Particle Size:** Microwaves have a particular wavelength and therefore are more easily reflected when hitting larger particle sizes. Therefore, sensors in applications with large particle sizes such as granulars are inherently more sensitive than those in applications with small particle sizes such as powders.

## MECHANICAL INSTALLATION

Before installing the **SFI**, be sure to read the Pre-Installation Considerations. Proper mounting selection is critical to achieving a successful installation. Generally, there are three mounting techniques which can be used: angular mounting at 25 to 45 degree, coupling mount at 90 degrees and saddle coupling mount at 90 degrees.

### Angular mount (20-45 degree) (see Figure 2):

- 1.) Create a "y" in the material handling line by cutting a hole and welding a suitable tube/pipe at a 25 to 45 degree angle with respect to the material flow.
- 2.) Position tube pointing downstream to help prevent plugging of the tube. The welded end of the tube should not project into the material flow. The tube should be kept as short as possible while still providing clearance for sensor mounting. The opposite end of the tube should have a fitting which will accept a 1-1/4" NPT (1-1/2" if using the stainless steel adapter) male connection found on the **SFI** sensor housing.
- 3.) Tighten the sensor into place ensuring the conduit connection is facing downward.

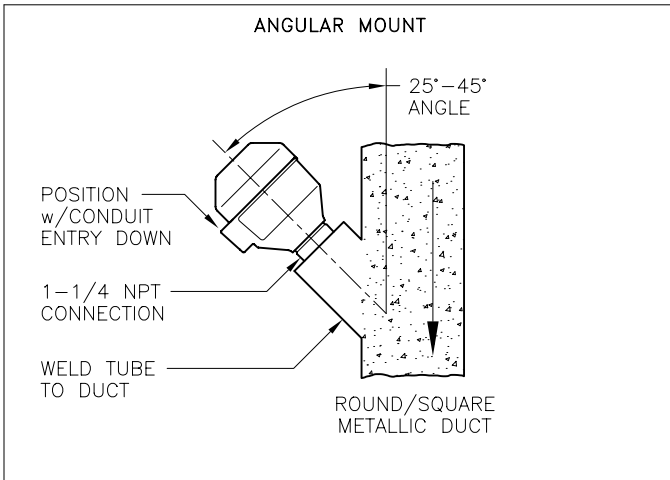

Figure 2

### Coupling mount (90 degree) (see Figure 3):

Although angled mounting is preferable, 90 degree mounting is acceptable in some applications. The **SFI** sensor housing incorporates an aluminum 1-1/4" NPT connection. The connection is specially machined to provide flush mount installation when installed into a standard 1-1/4" half coupling (1-1/2" coupling if using the stainless steel adapter). Tighten the sensor into the appropriate welded coupling ensuring the conduit connection is facing downward.

### Saddle coupling (90 degree) (see Figure 4):

Although angled mounting is preferable, 90 degree mounting is acceptable in some applications. Monitor's saddle coupling can be used to overcome the difficulty of welding to the curvature of the material handling line. The aluminum saddle coupling is threaded to permit engagement of the 1-1/4" NPT connection on the **SFI**. Using the supplied gasket, acceptable mounting can be achieved for pipe/chute diameters ranging from 4" to 10".

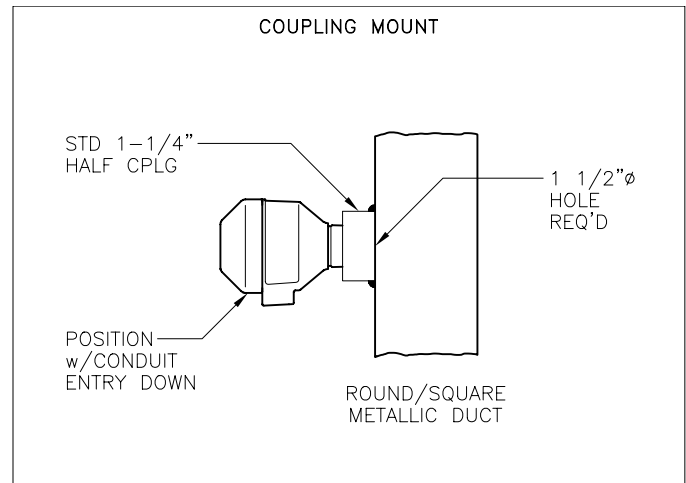

Figure 3

- 1.) After selecting the appropriate location, cut a 1 1/2" diameter hole in the pipe/chute.
- 2.) Position/center the saddle coupling over the hole while placing the gasket in between.
- 3.) Fasten the saddle coupling to the pipe/chute using industrial grade hose clamps.
- 4.) Tighten the sensor into the saddle coupling ensuring the conduit connection is facing downward.

The saddle coupling can also be fastened to a pipe/chute with standard screw/nut fasteners by simply creating mounting holes in the saddle coupling's "ears" and fastening to the pipe/chute. It is also feasible to flatten the profile of the saddle coupling (via belt sander, mill, etc.) and use it as a standard half coupling.

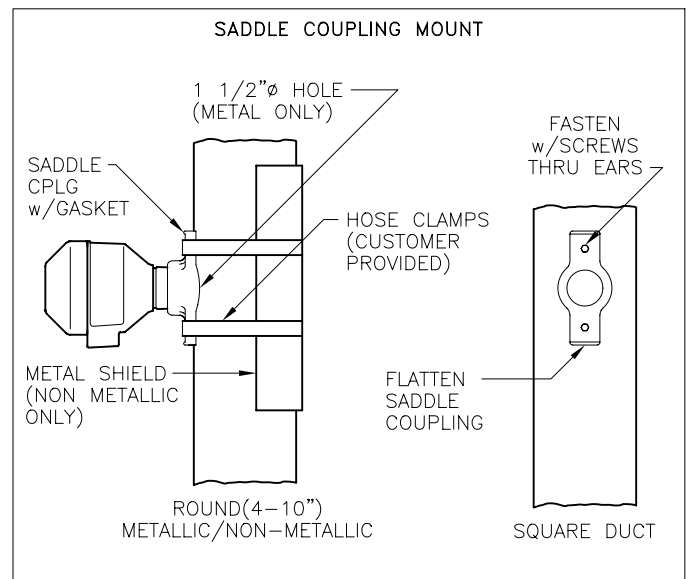

Figure 4

**Special Note for Mounting to Non-Metallic Chutes:** When sensing through non-metallic materials, the energy can travel through the pipe/chute to the backside of the installation. The sensor must be positioned to avoid having motion of nearby equipment or personnel interpreted as a disturbance. Backing the non-metallic pipe/chute with a metallic shield will greatly reduce the possibility of false signals.

## ELECTRICAL INSTALLATION

**1) Power (see Figure 5):** Two wire entries are provided for wiring convenience, especially if separation of power and output is required. Route wires through entry. While observing polarity, connect the DC voltage source to the “+” and “-” terminals located on the PCB. Improper interconnection may result in circuit damage. Connect the shield of your shielded cable to either the voltage source’s earth ground, or the ground post provided in the sensor. Connect only one end of the shield, leaving the other end unattached.

**2) Output (see Figure 5):** Route wires through conduit entry and connect the positive end of the analog output load to the “SIG” terminal and the negative end of the analog output load to the “-” terminal of the power supply. Note that the power source “-” and the analog output “-” are the same point. The sensor is acting as a current sourcing device. Isolation is provided between the sensor’s housing ground and the “-” terminal on the sensor’s PCB. See specifications for isolation value. The power source therefore provides the energy to operate the sensor and the energy needed to generate the current loop.

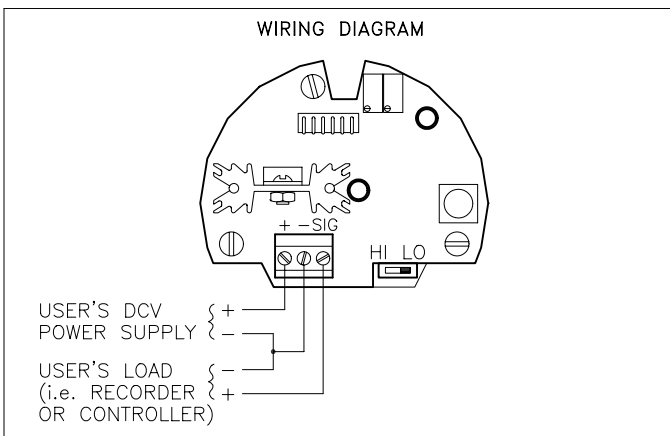

Figure 5

## CALIBRATION

Acceptable calibration is application dependent. It is expected that a good percentage of applications will not achieve an output ranging from 4-20mA. Although there are on-board adjustments designed to generate such, an acceptable application would include those whose current output may range from 4-10mA, 6-13mA, 10-19mA, etc.

**Note:** A 4mA output always represents a no-flow condition. The user’s control apparatus must make decisions from the current limits achievable by the application. The following adjustments can be utilized to optimize the current output.

**Sensitivity:** The switch selection chosen determines the amount of gain to be applied to the sensed signal. Adjustment is done via a slide switch which permits selection of “HI” or “LO” settings. Ideal selection can be determined only after the full flow status is created and analyzed. The sensor is provided with the sensitivity switch placed in the “LO” setting. If insufficient output current is observed at full flow condition, gain can be increased by repositioning slide switch to “HI”. Conversely, if output current is excessive at full flow condition, gain can be decreased by repositioning slide switch to “LO”.

**“Z” Zero Adjustment:** A multi-turn potentiometer is provided to fine tune the output current when in the no-flow condition. The intention of this adjustment is to make minor current changes when no motion is detected. The range of the adjustment is limited to +/- 10%. If the application’s “low motion” limit is greater than 4.5mA, this adjustment will not be capable of reducing the output current to the desired 4.0mA. Successful use of the **SFI** is still possible with proper signal analysis by the user’s control system.

**“S” Span Adjustment:** A multi-turn potentiometer is provided to fine tune the output current when in the full-flow condition. The intention of this adjustment is to make minor current changes when full motion is detected. The range of adjustment is limited to +/- 10%. If the application’s maximum motion limit is less than 18.4mA, this adjustment will not be capable of increasing the output current to the desired 20.0mA. Successful use of the **SFI** is still possible with proper signal analysis by the user’s control system.

**“SIG AVG” Signal Average Adjustment:** A single-turn potentiometer is provided to permit the user to set the time period over which the output signal should be averaged. Reaction to a step stimulus can be adjusted from 100mS up to 5 seconds. This is particularly useful for applications in which periodic surges are typical of the conveying process. The function operates as a “moving average” and therefore the output current may move sluggishly if SIG AVG is set relatively high.

### Indicators:

**1) Green LED:** Illumination of the green LED indicates that power is properly connected to the sensor. Lack of illumination could be from lack of supplied power or reversed polarity of the input connections.

**2) Yellow LED:** Any illumination of the yellow LED indicates that the “SIG” connection loop is correctly installed. Lack of illumination could be from improper connection between the sensor and the output apparatus. Detected motion will cause the yellow LED to more intensely illuminate.

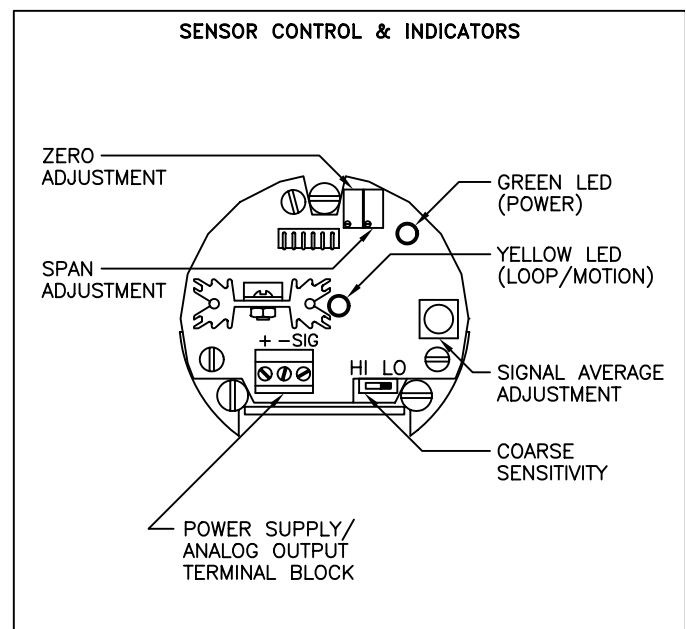

Figure 6

### Calibration Sequence:

- 1) **“Sensitivity” Setting:** Place the sensitivity setting in the LO position to start the process. It may be necessary to change to HI but it will become evident later in this sequence.
- 2) **“SIG ADJ” Setting:** Place “SIG ADJ” adjustment fully clockwise to achieve maximum averaging. During the following steps, allow 5 seconds of settling time after any adjustment before making conclusions.
- 3) **“Z” Setting:** While the system is operating (conveyors, feeders) and no material is flowing, adjust “Z” zero adjustment until output current reads 4.0mA. If machinery movement or equivalent “minimum flow” status creates significant motion, it may be impossible to attain the 4.0mA reading.
- 4) **“S” Setting:** With the material flowing in maximum condition, adjust the “S” span adjustment until output current reads 20.0mA. If detected motion is too little, it may be impossible to attain the 20.0mA reading.
- 5) **Sensitivity Setting:** Determine if the range between “no flow” and “full flow” conditions provide enough current output change. If not, readjust sensitivity setting to HI and repeat steps 3 and 4.
- 6) **“SIG ADJ” Setting:** Make final decision regarding placement of the signal averaging. If it is desirable to have the output current respond more quickly to activity at the sensor face, rotate the adjustment counter-clockwise.

## TROUBLESHOOTING

**Problem: The SFI output current does not change with process flow changes.**

### Cause/Solution:

- 1) Insufficient circuit gain for the detected motion. Increase the sensor sensitivity by selecting “HI” position.
- 2) Mounting location does not provide enough microwave disturbance. Consider whether a different mounting location or angle may present a better target and thereby increase the microwave disturbance/output current.

**Problem: The SFI output current changes erratically therefore creating unusable information.**

### Cause/Solution:

- 1) Sensor is reacting too fast to the instantaneous disturbances detected. Increase the signal averaging by rotating the “SIG AVG” potentiometer clockwise.
- 2) Mounting location sees inconsistent flow patterns generally associated with the application. Consider whether a different mounting location or angle may present a more consistent target for the determination of material flow.

**Problem: The SFI output current always remains below 10mA (e.g. no material flow is represented by 4mA and full flow is represented by <10mA).**

### Cause/Solution:

- 1) Insufficient circuit gain for the detected motion. Increase the sensor sensitivity by selecting the “HI” position.
- 2) Circuit scaling factor is not maximized. Increase the scaling factor (span) by rotating the “S” potentiometer clockwise.
- 3) Mounting location does not provide enough microwave disturbance. Consider whether a different mounting location or angle may present a better target and thereby increase microwave disturbance/output signal.

**Problem: The SFI output current always remains above 12mA (e.g. no material flow or minimum material flow is represented by >12mA and full flow is represented by 20mA).**

### Cause/Solution:

- 1) Circuit offset factor is excessive. Decrease the offset factor (zero) by rotating the “Z” potentiometer counter-clockwise.
- 2) Determine if equipment such as feeders or conveyors are being sensed when no flow or minimum flow is present resulting in a greater output current. Do so by evaluating output current with the system operating without material. If necessary, mount the sensor at new location.
- 3) Mounting location provides excessive material disturbance detection. Consider whether a different mounting location or angle may present a target which would not create as much microwave disturbance/output signal.

**Problem: The SFI output current hits maximum level of 20+mA prior to time when material flow is at maximum.**

### Cause/Solution:

- 1) Excessive circuit gain for the detected motion. Decrease the sensor sensitivity by selecting the “LO” position.
- 2) Mounting location provides excessive microwave disturbance. Consider whether a different mounting location or angle may present a target which would not create as much material disturbance/output signal.

# 834

## Model SFI

### MAINTENANCE

The **SFI** is a maintenance-free product and shall be serviced by Monitor Technologies LLC only. Consult the factory when operation appears inappropriate. The following warning is required by the Federal Communications Commission (FCC).

**WARNING:** Changes or modifications to the **SFI** not expressly approved by Monitor Technologies LLC could void the user's authority to operate the product.

**NOTE:** This equipment has been tested and found to comply with the limits for a Class B digital device, pursuant to Part 15 of the FCC Rules. These limits are designed to provide reasonable protection against harmful interference in residential and industrial installations. This equipment generates, uses and can radiate radio frequency energy and, if not installed and used in accordance with the instructions, may cause harmful interference in radio communications.

However, there is no guarantee that interference will not occur in a particular installation. If this equipment does cause harmful interference to radio or television reception, which can be determined by turning the equipment off and on, the user is encouraged to try to correct the interference by one or more of the following measures:

- Reorient or relocate the receiving antenna
- Increase the separation between the **SFI** and the receiver
- Connect the **SFI** to a circuit different from which the receiver is connected
- Consult the dealer or an experienced radio/TV technician for help

### SAFETY

#### Radiated Energy:

OSHA has adopted regulations designed to prevent possible harmful effects in human being from exposure to electromagnetic fields in the frequency range of 300 KHz to 100 GHz. The **SFI** generates energy within this band. OSHA permits human exposure to power densities up to 10mW/cm<sup>2</sup> for a one-half hour continuous duration. The **SFI** produces a power density less than 1mW/cm<sup>2</sup> at the sensor face and therefore poses no health danger to operators or the general public.

### SPECIFICATIONS

Power Requirements:	15-30 VDC, 100mA max.
Enclosure:	die cast aluminum, polyester coated (orange)
Enclosure Protection:	NEMA 4, IP66
Operating Temperature:	-13° to 185° F (-25° to 85° C)
Process Temperature:	250° F (121° C) if ambient air temp. below 150° F (+65° C)
Process Seals:	TFE Teflon®, Ryton®
Pressure Ratings:	
TFE Teflon®:	75psi intermittent
Ryton®:	300psi
Process Connection:	1-1/4" NPT (1-1/2" with stainless steel adapter)
Conduit Connections:	(2) 1/2" NPT
Detection Range:	0 to 10' free air, environment and target dependent
Sensitivity:	switch selectable HI/LOW
Min. Velocity:	2.5 ft/sec
Output:	4-20mA output (full span may not be achievable in some applications), current sourcing device (signal return common to user power supply); magnitude proportional to disturbance detected; 175 ohm load max, zero and span adjustable
Isolation:	750 vpk isolation between sensor ground and user power supply/ 4-20mA supply
Indicators:	Green LED - power Yellow LED - loop, intensifies with disturbance detected
Emission:	24.125 GHz, FCC and IC certified, energy levels less than 1mW/cm <sup>2</sup> (OSHA limit of 10mW/cm <sup>2</sup> )
Approvals:	FM, CSA; Class II, Div. 1 & 2, Groups E, F, G; CE Marking

Teflon® and Ryton® are registered trademarks of Dupont Chemical Co.

### WARRANTY

Monitor Technologies LLC warrants each solids flow indicator it manufactures to be free from defects in material and workmanship under normal use and service within two (2) years from the date of purchase within North America, and within one (1) year from date of purchase outside of North America. The purchaser must give notice of an defect to Monitor Technologies LLC within the warranty period, return the product intact and prepay transportation charges. The obligation of Monitor Technologies LLC under this warranty is limited to repair or replacement at its factory. This warranty shall not apply to any product which is repaired or altered outside of the Monitor Technologies LLC factory, or which has been subject to misuse, negligence, accident, incorrect wiring by others or improper installation.

Monitor Technologies LLC reserves the right to change the design and/or specifications without prior notice.



834A.VER5.1100.5M