



SAFETY INSTRUCTIONS

1. Depressurize and vent system prior to installation or removal.
2. Confirm chemical compatibility before use.
3. Do not exceed maximum temperature/pressure specifications.
4. Wear safety goggles or faceshield during installation/service.
5. Do not alter product construction.



1.0 Description

The 2551 Magmeter measures the flow rate in a full pipe by monitoring the voltage produced when the (conductive) fluid moves through a magnetic field.

Output options include a traditional frequency signal, a serial data (digital) output, and a 4-20 mA output.

The 2551 Magmeter is available in three sizes that will accommodate pipes from 1/2 inch through 12 inch diameters.

Select from four different material combinations to match the magmeter to the application requirements.

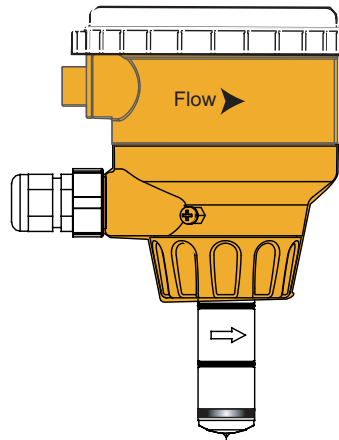

Contents

1.0 Description	1	7.0 Setup Menu	10
2.0 Specifications	2	7.1 Averaging and Sensitivity	11
3.0 Installation: Pipe fittings	3	7.2 Bi-Directional Flow	12
3.1 Location of Fitting	3	7.3 Calibration Data	12
3.2 Empty Pipe Detection	3	8.0 Calibration Menu	14
4.0 Overview of 2551 Display versions	4	8.1 Volume method of calibration	14
5.0 Wiring	5	8.2 Rate method of calibration	14
5.1 Basic Wiring	5	9.0 Relay Menus	15
5.2 Wiring: Mirror Relay 1 output	5	9.1 Pulse Relay mode	15
5.3 2551 and other manufacturer's instruments	5	9.2 Total Relay mode	15
5.4 Wiring to Signet Flow Instruments	6	9.3 High, Low, or Window Relay modes	16
5.5 Wiring Relays	7	10.0 Test Menu	17
6.0 View Menu	8	11.0 Options Menu	17
6.1 Resetting the Resettable Totalizer	8	11.1 Output Modes	17
6.2 Navigating the Menus	9	12.0 Technical Information	18
6.3 Keypad Functions	9	12.1 Grounding	18
6.4 Security Code	9	12.2 Maintenance	19
		12.3 Troubleshooting	19
		13.0 Ordering Information	20

2.0 Specifications

Wetted Materials:

- Sensor body and Electrodes and Grounding ring:
 - P0, -P1, -P2: Polypropylene and 316L SS
 - T0, -T1, -T2: PVDF and Titanium
 - V0, -V1, -V2: PVDF and Hastelloy-C
 - W0, -W1, -W2: PVDF and 316L SS
 - O-rings: FPM (standard)
EPDM, Kalrez® (optional)

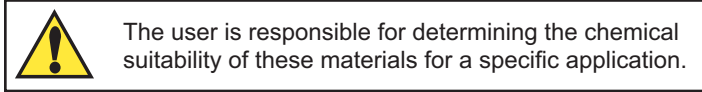

- Case: PBT
- Display window: Polyamide

Power Requirements

- 4 to 20 mA: 21.6 to 26.4 VDC, 22.1 mA max.
400 mV p-p maximum ripple voltage
- Frequency: 5 to 26.4 VDC, 15 mA max.
- Digital: 5 to 6.5 VDC, 15 mA max.
- Auxiliary (only required for units with relays):
9 to 24 VDC, 0.4A max
- Reverse polarity and short circuit protected

Performance

- Pipe size range: DN15 to DN300 (½ to 12 in.)
- Flow Range (Bi-directional)
Minimum: 0.05 m/s (0.15 ft/s)
Maximum: 10 m/s (33 ft/s)
- Linearity: ±1% of reading +0.01m/s (0.033 ft/s)
- Repeatability: ±0.5% of reading @ 25°C (77°F)
- Minimum Conductivity: 20 µS/cm

Output Specifications

Current output (4 to 20 mA)

- Max Loop Resistance: 300Ω
- Loop Accuracy: 32 µA max. error (25°C @ 24 VDC)
- Temp. drift: ±1 µA per °C max.
- Power supply rejection: ±1 µA per V
- Isolation: Low voltage <48 VAC/DC
from electrodes and aux power
- Maximum cable: 300 m (1000 ft.)
- Error condition: 22.1 mA

Frequency output:

- Output modes: Freq, Freq+10, or Mirror Relay 1
- Max. Pullup Voltage: 30 VDC
- Reverse Polarity Protected to -40 V
- Max. Current Sink: 50 mA, current limited
- Maximum cable: 300 m (1000 ft.)

Digital (S³L) Output:

- Serial ASCII, TTL level 9600 bps
- Compatible with Signet 8900

Standards and Approvals

- CE
- UL, CUL (for display versions with relays)
- NEMA 4X / IP65 Enclosure (with cap installed)
- EMC: EN55011: 1998 +A1:99+A2:02
Class B Emissions
EN61326: 1997 +A1:98+A2:01
EN61000-6-2:2001
- Safety: EN61010-1:2001
- U.S. Patent No. 7,055,396 B1

Relay Specifications

- Relay 1 and 2 Type: Mechanical SPDT
Rating: 5 A @ 30 VDC max., 5 A @ 250 VAC max.
- Relay 3 Type: Solid State
Rating: 50 mA @ 30 VDC, 50 mA @ 42 VAC
- Hysteresis: Adjustable, plus timer delay
- Trigger Delay: Adjustable (0 to 9999.9 sec.)

Relay Modes: Off, Low, High, Window, and Proportional Pulse
Relay Source: Flow Rate, Resettable Totalizer
Error Condition: Selectable; Fail Open or Fail Closed

Display

- Characters: 2 x 16
- Contrast: User-set in four levels
- Backlighting (only on relay versions):
Requires external 9-24 VDC, 0.4 mA max.

Environmental Requirements

- Storage Temperature: -20° to 70°C (-4° to 158°F)
- Relative Humidity: 0 to 95% (non-condensing)
- Operating Temperature
 - Ambient: -10° to 70°C (14° to 158°F)
 - Media: 0° to 85°C (32° to 185°F)
- Max. operating pressure:
10.3 bar @ 25°C (150 psi @ 77°F)
1.4 bar @ 85°C (20 psi @ 185°F)

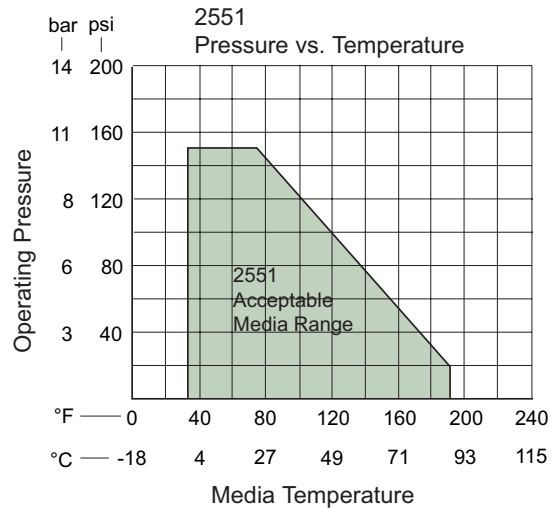



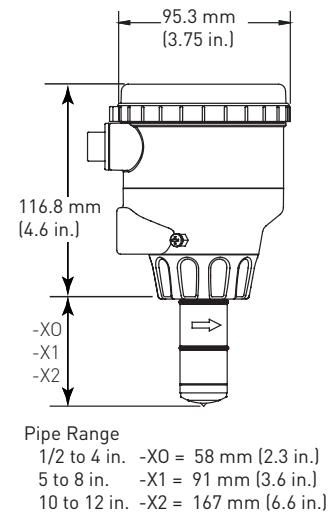







Dimensions



X = Sensor Body P, T, V, or W

3.0 Installation: Pipe fittings

George Fischer Signet offers a wide selection of installation fittings that control the position of the magmeter electrodes in relation to the dimensions of the pipe. You will find a complete list of order numbers for installation fittings in the K-factor table in section 7.3.

Type	Description	Type	Description
Plastic tees 	<ul style="list-style-type: none"> 0.5 to 4 inch versions PVC or CPVC 	Iron, Carbon Steel, 316 SS Threaded tees 	<ul style="list-style-type: none"> 0.5 to 2 in. versions Mounts on threaded pipe ends
PVC Glue-on Saddles 	<ul style="list-style-type: none"> Available in 10 and 12 inch sizes only Cut 2-1/2 inch hole in pipe Weld in place using solvent cement 	Carbon steel & stainless steel Weld-on Weldolets 	<ul style="list-style-type: none"> 2 to 4 inch, cut 1-7/16 inch hole in pipe Over 4 inch, cut 2-1/8 inch hole in pipe
PVC Saddles 	<ul style="list-style-type: none"> 2 to 4 inch, cut 1-7/16 inch hole in pipe 6 to 8 inch, cut 2-1/8 inch hole in pipe 	Fiberglass tees & saddles: FPT  FPS 	<ul style="list-style-type: none"> 1.5 in. to 8 in. PVDF insert > 8 in. PVC insert
PP Clamp-on Saddles 	<ul style="list-style-type: none"> Available in 10 and 12 inch sizes only Cut 2-1/8 inch hole in pipe 	Metric Union Fitting 	<ul style="list-style-type: none"> For pipes from DN 15 to 50 mm PP or PVDF
Iron Strap-on saddles 	<ul style="list-style-type: none"> 2 to 4 inch, cut 1-7/16 inch hole in pipe Over 4 inch, cut 2-1/8 inch hole in pipe 		

3.1 Location of Fitting

The 2551 can only measure flow if the pipe is full.

If the piping system has entrained air pockets, take steps to locate the sensor so the air pockets will not contact the electrodes.

Select a location with sufficient distance of straight pipe immediately upstream of the sensor.

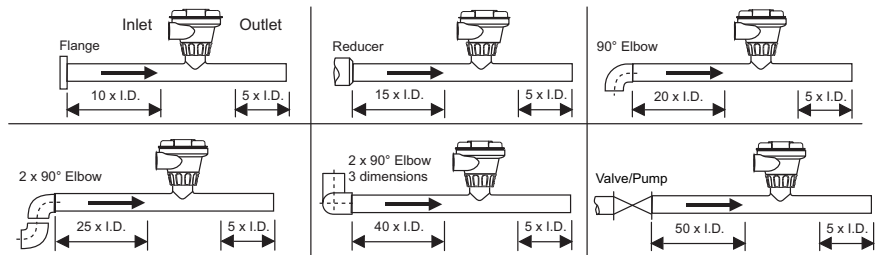

These configurations guarantee that the pipe is always filled. The sensor cannot be exposed to air bubbles.

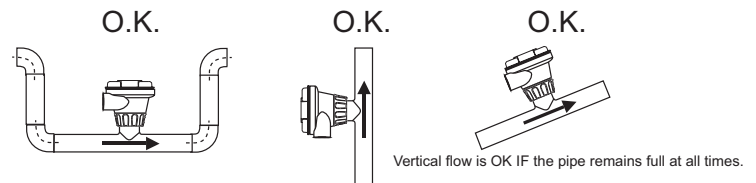

Avoid these situations unless you are certain that the sensor will not be exposed to air bubbles.

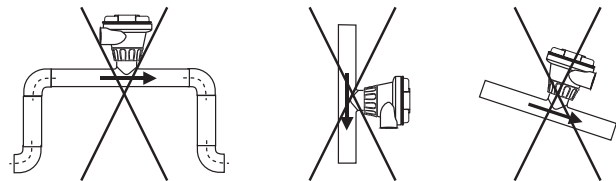

In a gravity-flow system, the tank must be designed so the level does not drop below the outlet. This causes the pipe to draw air in from the tank. If air bubbles pass across the Magmeter electrodes, the output will become erratic.

3.2 Empty Pipe Detection

If the pipe is not full, or the electrodes are not immersed, the flow display will show zero and all output functions will behave accordingly.

If the magmeter electrodes are exposed to flow transitions and air bubbles, the measurement may be incorrect until the conditions are stabilized.

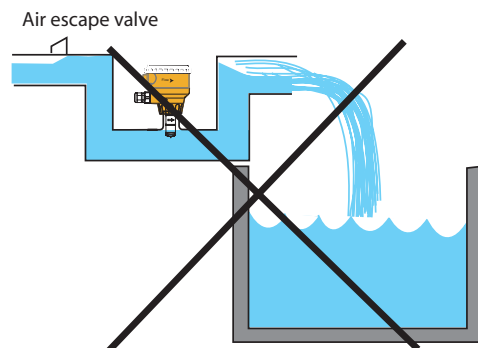

4.0 Overview of 2551 Display Magmeter

2551 Display Magmeters use a dual-sided electronics module and dual conduit ports. Unused ports must be sealed to protect the electronics from water damage.

- ① The lower set of conduit ports provide access to the wiring terminals for:
 - Loop Power
 - Flow Output Signal (current loop, frequency or Mirror Relay 1 output).
- ② The upper set of conduit ports provide access to the wiring terminals for:
 - Relay output wiring
 - Auxiliary power for relay coils and display backlight
- ③ The sensor is marked with a directional arrow to indicate the direction identified as forward flow. An adhesive decal is also provided that can be affixed to the pipe to indicate the direction of forward flow. Flow in the opposite direction from the arrow will be identified as reverse flow on the display by a "-" symbol.
- ④ The terminals in the magmeter are designed to accommodate 16 to 22 AWG conductors.
- ⑤ The display includes two LEDs that light when Relay 1 or Relay 2 are activated.
 - All three relays can be monitored by scrolling to the Relay Status display located in the View menu.
 - If the Language option has not been made, new magmeters will always open with the Select Language display.

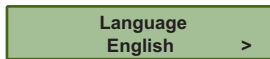

- ⑥ The part number, serial number and output type are identified on the electronics module.

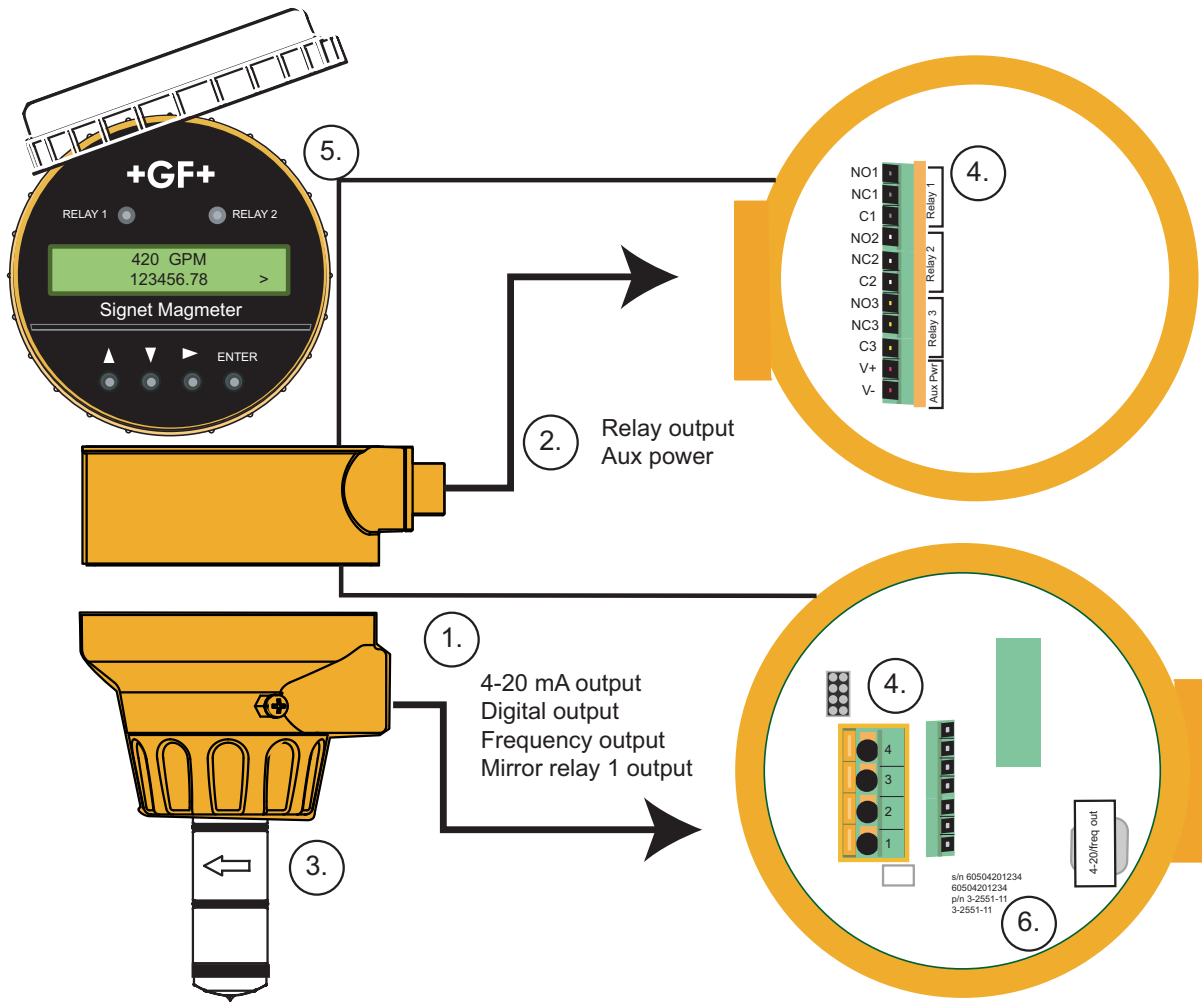

5.0 Wiring

5.1 Basic Wiring

Frequency output

- 3-2551-21 and 3-2551-41 Magmeters may be programmed to provide an open collector FREQUENCY output.
- The maximum frequency output is 1000 Hz (@ 10 meters per second)
- If the Frequency ÷ 10 output is selected, the maximum frequency is 100 Hz (@ 10 meters per second)
- AUX PWR must be connected to power the display backlighting and to power the relay coils if included.

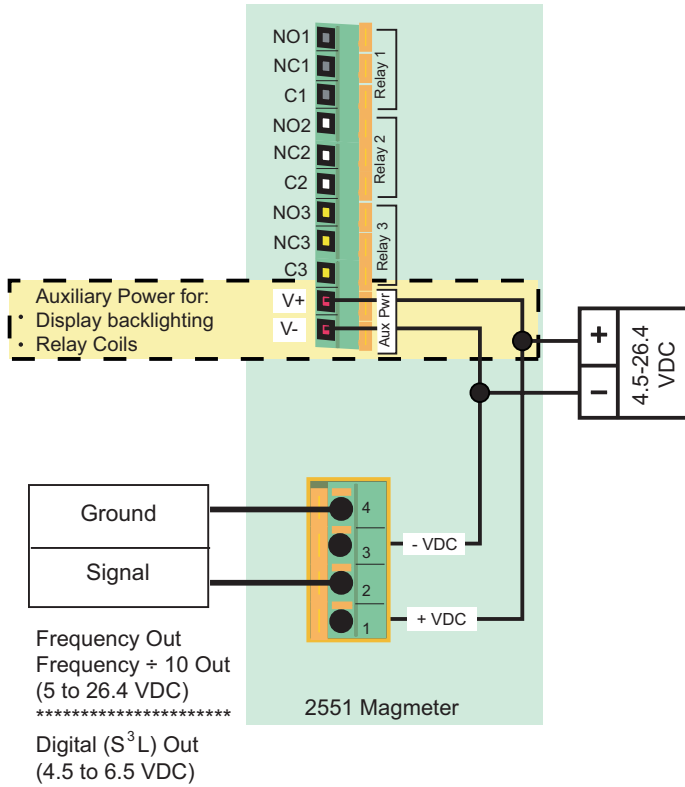

4-20 mA output

The 3-2551-22 and 3-2551-42 Magmeters provide a passive 4-20 mA loop output.

- External loop power (24 VDC) is required.
- Factory standard calibration is 4 - 20 mA = 0 - 5 m/s.
- The 4-20 mA output can be spanned to any range, from -10 m/s to +10 m/s.
- AUX PWR must be connected to power the display backlighting and to power the relay coils if included.

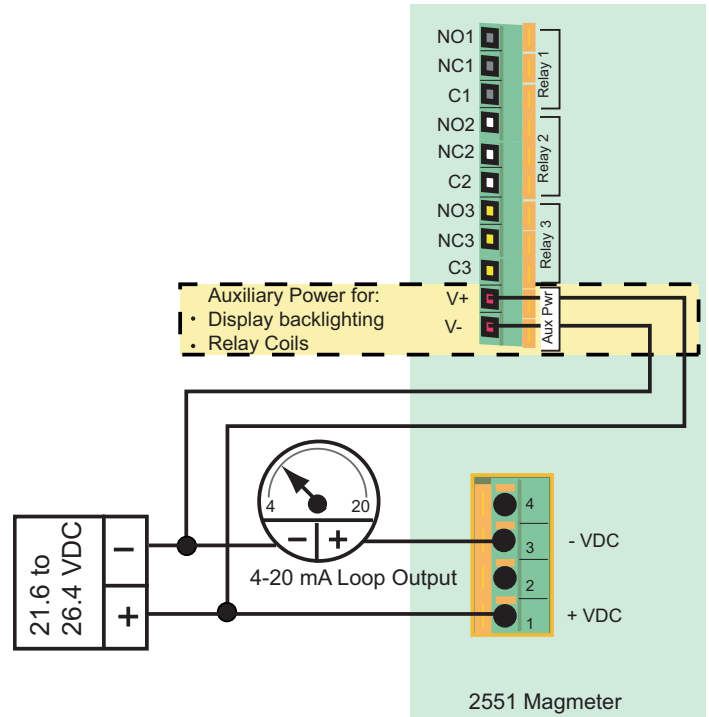

5.2 Wiring: Mirror Relay 1 output

The 3-2551-21 and -41 Magmeter can be configured to provide an Open Collector output in lieu of the sensor signal provided by Frequency or Digital output selections. The Open Collector Output can be programmed via the Relay 1 menu.

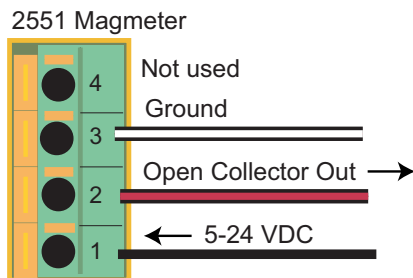

5.3 2551 and other manufacturer's instruments

When using the 2551 in a system with other manufacturer's equipment, a pull-up resistor may be required to power the open collector output.

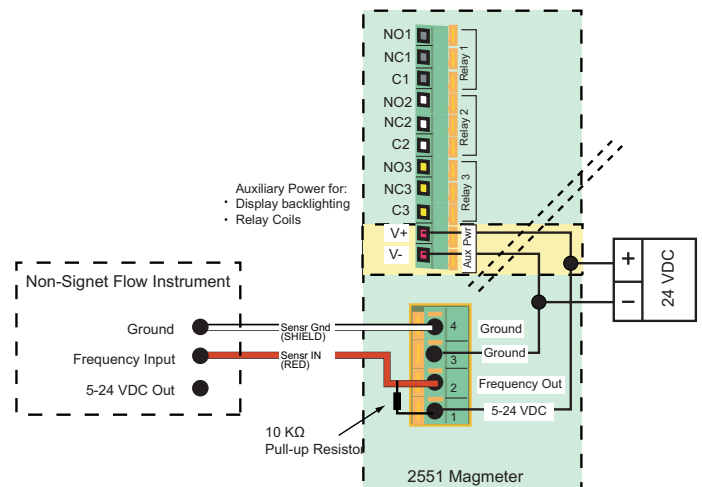

5.4 Wiring to Signet Flow Instruments

2551 and 8900 Multi-Parameter Controller: Frequency Out

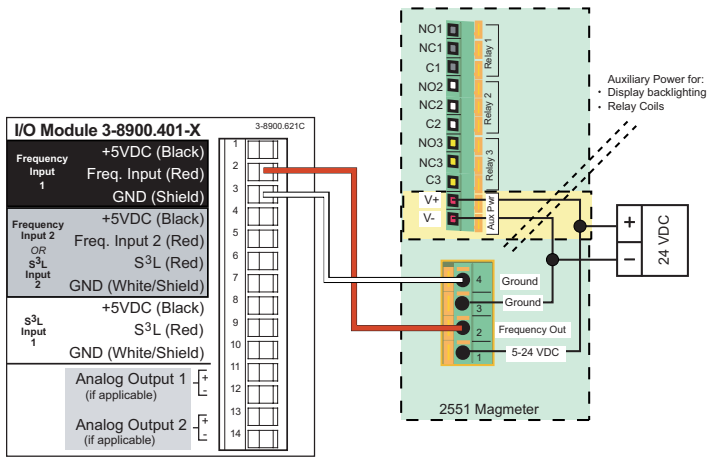

2551 and 8900 Multi-Parameter Controller: Digital Out

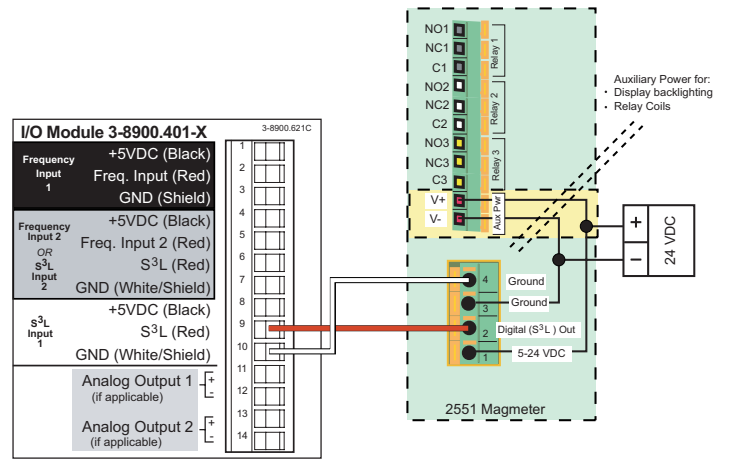

2551 and ProcessPro 8550 Flow Transmitter

When connecting the 2551 to any 8550 model, the AUXILIARY power in the 8550 must always be connected.

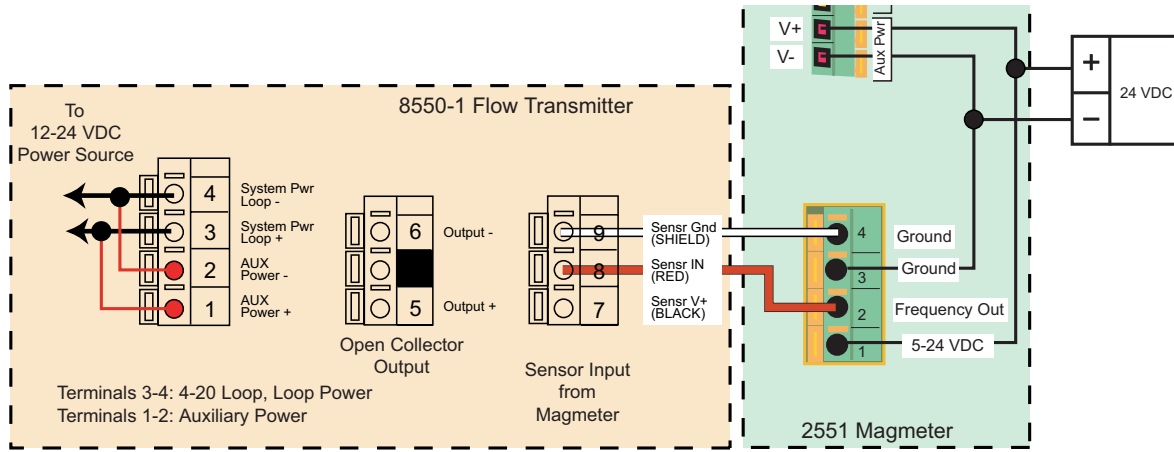

2551 and ProPoint 5075, 5500, 5600

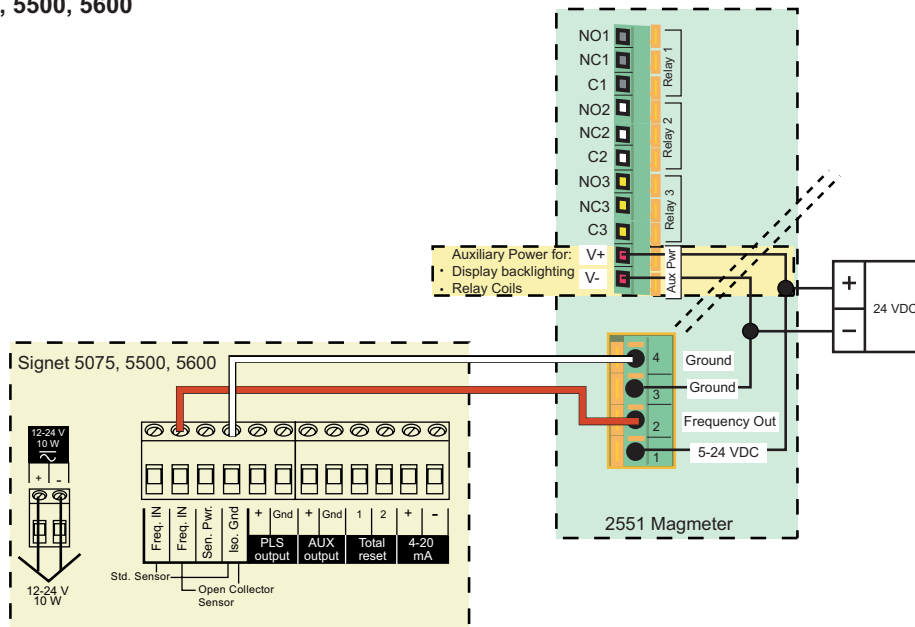

5.5 Wiring Relays

Relay 1, Relay 2 Type: Mechanical SPDT
 Rating: 5A @ 30 VDC max., 5 A @ 250 VAC max

Relays 1 and 2 are dry contact relays rated for 5 A maximum current.
 Relays 1 and 2 are best suited for switching high voltage loads, such as AC powered pumps and valves.

When used to switch inductive loads, dry contact relays may be damaged by arcing. Signet recommends the installation of a filter device to prevent such damage.

3-8050.396 159 000 617 RC Filter kit (for relay use)

Relay 3 Type: Solid State
 Rating: 50 mA @ 30 VDC, 50 mA @ 42 VAC

Relay 3 is a solid state relay. It can be applied exactly the same as a dry contact relay, but the current rating is 0.2 A (200 mA) maximum. Relay 3 is best suited to pulse applications and low voltage loads.

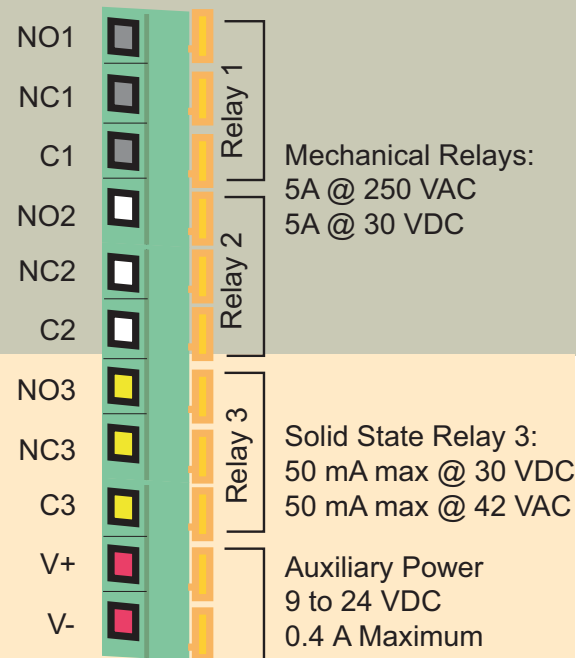

Auxiliary power must be connected to operate the relays and to power the display backlighting. Auxiliary power is fully isolated. The Loop Power supply may be used for Aux power if the power source provides a sufficient current rating.

Relay Terminal Legend:
NO: Normally Open
NC: Normally Closed
C: Common

Application Notes: Relay Wiring

- Inductive relay loads may generate transient voltage spikes well in excess of the relay contact ratings. This will cause arcing across the contacts and consequently rapid relay wear. Signet recommends a RC-style filter ("snubber"), installed as illustrated here.
- The filter kit (3-8050.396) is available as an accessory item. See ordering information on back cover.
- Signet product warranty does not cover damage to relays due to contact burnout.

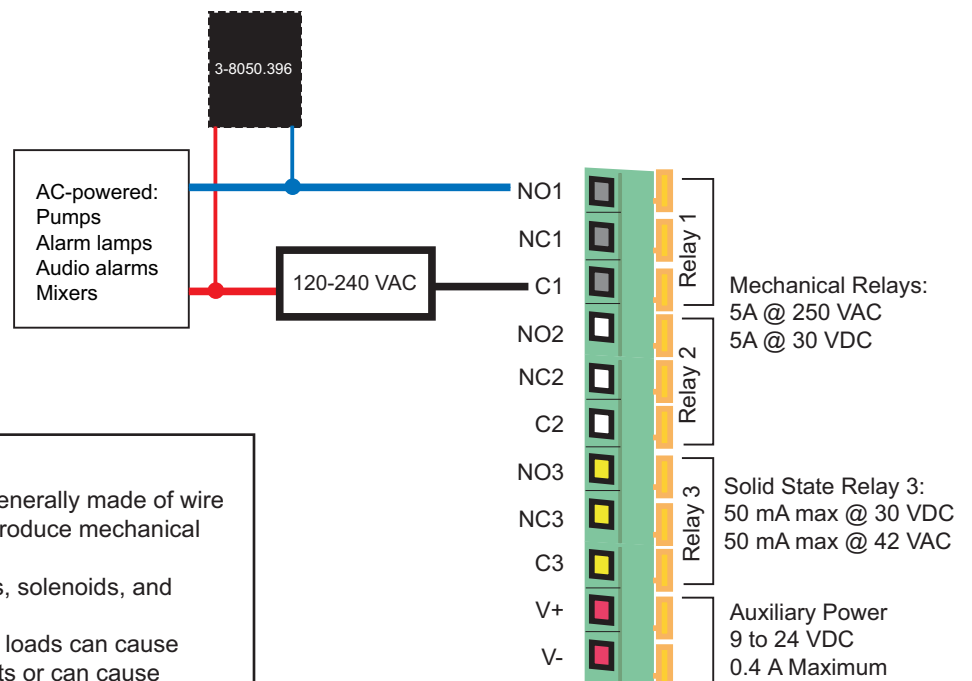

Definition:

An **inductive load** is an electrical device generally made of wire that is coiled to create a magnetic field to produce mechanical work when energized.

Examples of inductive loads include motors, solenoids, and relays.

High voltage transients from these types of loads can cause arcing across mechanical switching contacts or can cause damage to solid-state contacts.

6.0 View Menu

The VIEW menu contains all of the basic information available from the magmeter.

- The normal operating display shows the FLOW RATE on the top line of the display and the Resetable Totalizer on the lower line of the display.
- The Right Prompt symbol (>) always indicates a sub-menu associated with the current display. In this display it points the way to the TOTALIZER RESET function. See section 6.1 for detailed instructions.
- With AUXILIARY power connected to the magmeters with Relays, the display will be backlit. There is no switch to turn the backlight off.
-  A flashing character or text on the display indicates that the item is being edited. This manual uses a (red) star to illustrate a flashing display.
- The following information is viewed by scrolling UP or DOWN. These displays will remain in the display for 10 minutes, then the normal operating display will return.

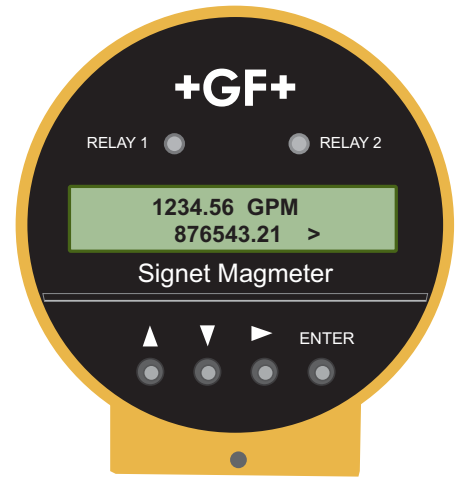

Show the permanent total. This totalizer cannot be reset.

Shows the current output. For 4-20 mA Output models only.

Relay States shown for units with a relay board.

This display is a reminder to visit the Signet website for updates and information about Signet products.

Enter menus from this display. See section 6.2.

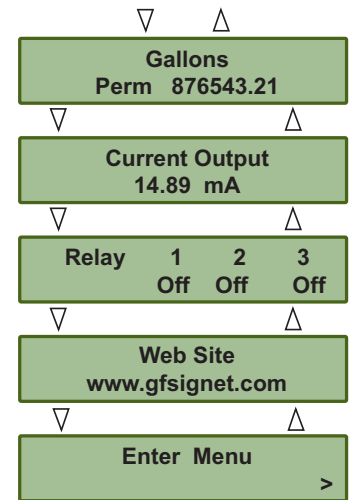

6.1 Resetting the Resetable Totalizer

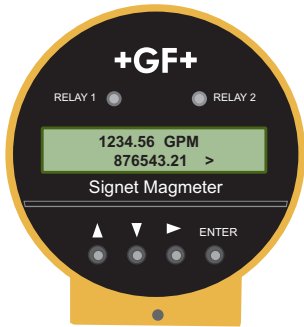

- From the normal operating display, press the RIGHT arrow key.
- The resetable totalizer can be configured to require the security code before allowing the reset. If the Total Reset set to "RESET OFF" this display will not appear. See section 11, Options Menu for instructions.
- Press any arrow key to toggle the flashing selection from NO to YES.
- Press the ENTER key. The totalizer will reset to 000000.00 and the display will immediately return to the normal operating display.

6.2 Navigating the Menus

Normal Operation Display

The normal operating display shows the Flow Rate on the top line and the Resettable Totalizer on the bottom line.

- All menu instructions in this manual assume that the instrument is showing this display.

2551 Menu Directory

The 2551 magmeter uses seven main menus to provide access to the calibration and programming features. Each menu serves a specific function.

Starting from the normal operating display, there are two ways to access the menus:

- Press the UP arrow key to scroll to the Enter Menu display, then press the RIGHT arrow key.
- Press the ENTER key and hold it for about three seconds.

Setup Menu

This menu contains all of the settings and information that the magmeter requires to operate, including the K-factor, the totalizer settings, low flow cutoff, and several display

Calibration Menu

The Calibration menu provides two different methods for adjusting the calibration. See section 8.0 for details related to this menu.

Relay Menus

Each of the available relays in the 2551-21 and -22 are programmed from their own dedicated menu. See section 9 for details related to these menus.

Note: Menu items associated with Relay 2 and relay 3 are suppressed in models without relays. See section 9.0 for details related to this menu.

Test Menu

The Test menu is used to manually toggle relays or to induce a known value out of the 4-20 mA terminals. See section 10.0 for details related to this menu.

Options Menu

The Options menu contains those settings and values that are usually programmed during the initial installation, and then seldom modified, including the SECURITY CODE (see section 6.4). See section 11.0 for details related to the Options menu.

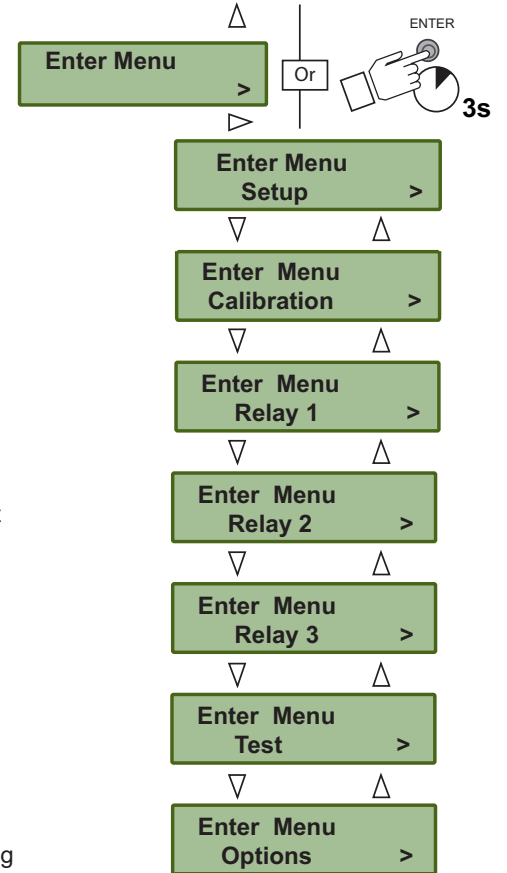
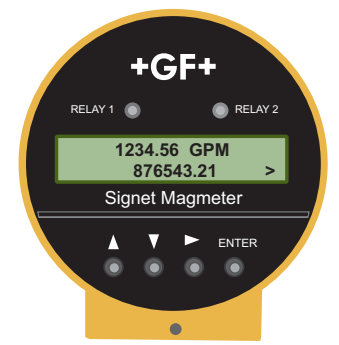

6.3 Keypad Functions



Scrolls UP through any menu. If the display shows any flashing character or selection, scrolls UP to the previous value or selection.



Scrolls DOWN through any menu. If the display shows any flashing character or selection, scrolls DOWN to the next value or selection.



Press the UP and DOWN keys together to abandon any unsaved edits and return to the previous display.



Opens the menu currently being displayed. In Edit modes, advances the flashing character. In menus with only two options (Yes or No, On or Off) toggles between selections.

ENTER Saves a new selection in any menu. From Normal Operation display, jumps to first selection in Menu directory (when held for three seconds)

6.4 Security Code

The 2551 has a security code that can be programmed to any four digit numerical value.

- The factory setting is 0-0-0-0.
- To program the security code go to the Options menu.
- The security code will be required to edit any of the items in the menus. It is required only once for each editing session.
- Record the custom security code here or in a safe location.
- If the security code is lost, contact your Signet service center for instructions.



Security Code _____

WRITE IT DOWN!

7.0 Setup Menu

The Setup menu contains all of the parameters necessary for the 2551 Magmeter to begin measuring flow.

NOTE: The Security Code must be entered before any changes can be made to the Setup menu. See the Options menu in section 11 for details.

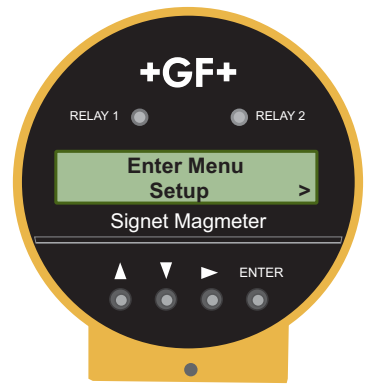

Use the keypad to navigate through each setting.

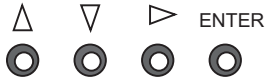

The values shown for each menu item represent the factory standard setting. All 2551 magmeters are packaged with these settings.

K-Factor: See the charts in section 7.3 for values in pulses per U.S. Gallon or in pulses per Liter. To use other units, convert the published values as appropriate.



Pipe Size: Select the pipe size that is nearest to the nominal pipe size.

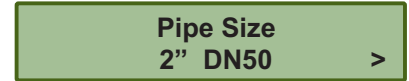

Flow Units: Set the units for the application. Four characters are available. The first three characters can be set to any symbol or alpha character, upper or lower case. The following special symbols are located between the upper case and lower case menus:

- (centered dot) μ (micro) _ (blank)
- (dash) / (slash) 3 (for cubic units)

The last character selects the timebase for the flow rate measurement. Select S/s (seconds) M/m (minutes), H/h (hours) or D/d (days)



Set 4 mA: In the 2551-22 and 2551-42 versions only, set the flow rate where the current output will be 4 mA.



Set 20 mA: In the 2551-22 and 2551-42 versions only, set the flow rate where the current output will be 20 mA.



The 4-20 mA output may be spanned to monitor forward and reverse flow rates.

Total Factor: Set the factor by which the totalizer will count. This setting is made in the application units (ie; gallons, liters, etc..)



Totalizer Units: Set the Totalizer Units. This setting serves as a label for the totalizer displays only. It has no effect on the measurement. The special characters listed in the Total Factor settings are available here also.

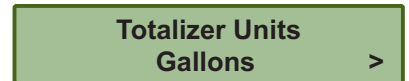

Low Flow Cutoff: Set a flow rate that the 2551 Magmeter will use as a minimum threshold. If the flow rate falls below this value, the 2551 will respond as if the flow were zero.

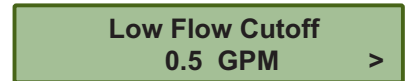

Averaging: Set the averaging period based on the installation and flow conditions. Smaller values allow the 2551 to respond to changes in flow rate quickly, while larger values smooth the fluctuations caused by installation and flow conditions. See section 7.1 for details.

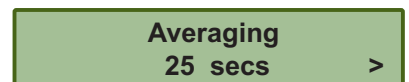

Sensitivity: Set a percentage of maximum range by which the flow must change to override the averaging feature and "jump" quickly to the new flow rate. See detailed explanation in section 7.1.



7.1 Averaging and Sensitivity

Even the most carefully engineered flow systems may experience erratic and unstable conditions. If the instability is communicated to the output functions, the results may create problems for control devices.

To alleviate these issues, the 2551 provides two adjustments that operate in tandem. The information here will help in determining the appropriate settings for any specific application.

Averaging

- The AVERAGING setting dictates the time over which the magmeter will average the flow signal. The LCD display is updated every second. With averaging at 14 seconds, the flow rate on the display is an average of the previous 14 seconds input.

Short averaging times provide the fastest display and output response to changes in the flow rate.

Higher averaging times help to smooth the display and current output where the flow in the pipe is erratic or unstable due to installation limitations.

Sensitivity

- The SENSITIVITY setting determines how the 2551 responds to sudden surges in the flow rate. It "overrides" the Averaging function just long enough to allow an actual change in flow rate to be displayed, then resumes the averaging. The result is a smooth flow display and a quick response to large shifts in the flow rate.

The settings for Sensitivity represent a percentage of the magmeter's maximum range, or 10 m/s.

Example: A sensitivity setting of 25% means that the flow rate must change instantly and by more than 2.5 m/s before the function is enabled.

NOTE: The SENSITIVITY function is ineffective if the Averaging function is set to zero.

No Averaging

With AVERAGING set to zero, the flow rate will be displayed immediately and with no filtering. This line represents the actual output of the flow sensor as it responds to unstable flow conditions in the pipe.

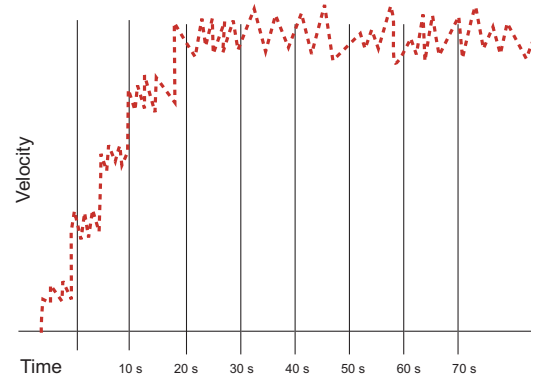

Averaging Only

With AVERAGING set to 50 seconds and SENSITIVITY still set to zero the flow rate is stabilized, but a sharp change in flow rate is not represented on the display or at the output for 50 seconds or longer.

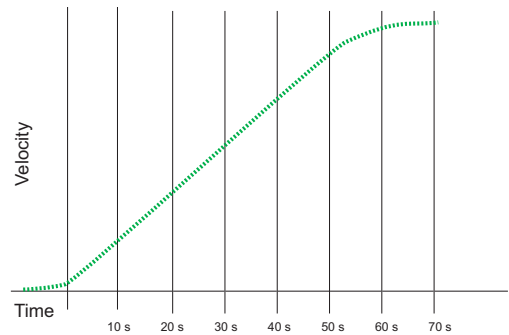

Averaging and Sensitivity

With AVERAGING at 50 seconds and SENSITIVITY set to 25%, the flow rate is stabilized, while the sudden shift in flow is reflected very quickly.

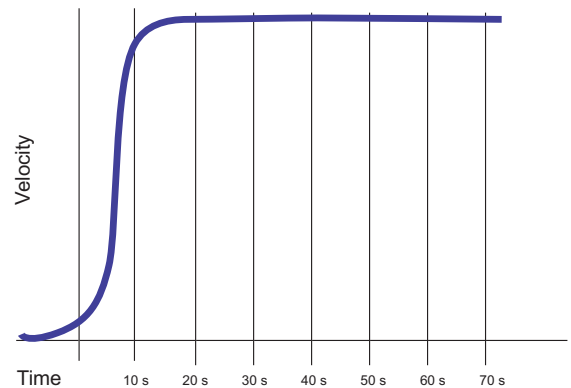

CAUTION

The SENSITIVITY function changes the response characteristics of the magmeter. If used as part of a tuned closed loop control system such a change may be undesirable.

7.2 Bi-Directional Flow

- The 2551 magmeter is designed to measure bi-directional flow.
- The forward flow direction is indicated by the directional arrow molded into the side of the 2551 sensor.
- The conduit ports are assembled at the factory to point UPSTREAM. They may be reversed by disassembling the components of the magmeter and reassembling.

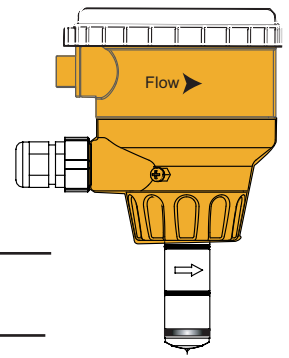

Flow Rate Display: The "+" sign is suppressed during forward flow.
"-123.45 GPM" during reverse flow.

Totalizer Display: The totalizer will count during forward flow conditions only.
During reverse flow the totalizer will not increment.

Relay Outputs: May be set to detect reverse flow: "Low Setpoint at -25GPM."

4-20 mA output: May be scaled to span any flow range:
For example: "4 to 20 mA = -100 GPM to +100 GPM"

Frequency output, Frequency ÷ 10 output: Reverse flow is processed same as forward flow in the frequency output magmeters.

Digital (S3L) output: Reverse flow results in 0 flow rate output.

7.3 Calibration Data: K-factors

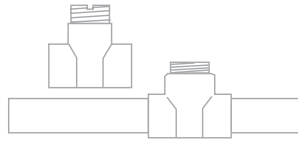

Carbon Steel Tees and Weld-o-Lets Stainless Steel Tees and Weld-o-Lets Galvanized Iron Tees

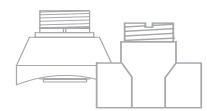

PVC Tees and Saddles

PIPE SIZE (IN.)	FITTING TYPE	K-Factor Gallons	K-Factor Liters
SCH 80 PVC TEES FOR SCH 80 PVC PIPE			
½	PV8T005	2289.37	604.85
¾	PV8T007	1430.41	377.92
1	PV8T010	876.86	231.67
1¼	PV8T012	447.06	118.11
1½	PV8T015	324.19	85.65
2	PV8T020	206.69	54.61
2½	PV8T025	131.46	34.73
3	PV8T030	82.52	21.80
4	PV8T040	44.78	11.83

SCH 80 PVC TEES FOR SCH 80 CPVC PIPE

½	CPV8T005	2496.03	659.45
¾	CPV8T007	1381.48	364.99
1	CPV8T010	857.98	226.68
1¼	CPV8T012	445.17	117.61
1½	CPV8T015	325.56	86.01

SCH 80 PVC SADDLES FOR SCH 80 PVC PIPE

2	PV8S020	193.83	51.21
2½	PV8S025	138.01	36.46
3	PV8S030	83.89	22.16
4	PV8S040	40.88	10.80
6	PV8S060	22.53	5.95
8	PV8S080	12.52	3.31
10	PV8S100	7.94	2.10
12	PV8S120	5.71	1.51

SCH 80 PVC SADDLES FOR SCH 40 PVC PIPE

2	PV8S020	180.01	47.56
2½	PV8S025	123.72	32.69
3	PV8S030	75.81	20.03
4	PV8S040	41.87	11.06
6	PV8S060	19.71	5.21
8	PV8S080	11.73	3.10
10	PV8S100	7.43	1.96
12	PV8S120	5.23	1.38

PIPE SIZE (IN.)	FITTING TYPE	K-Factor Gallons	K-Factor Liters
CARBON STEEL TEES ON SCH 40 PIPE			
½	CS4T005	1572.66	415.50
¾	CS4T007	1086.73	287.11
1	CS4T010	582.34	153.86
1¼	CS4T012	377.48	99.73
1½	CS4T015	267.79	70.75
2	CS4T020	167.85	44.35

STAINLESS STEEL TEES ON SCH 40 PIPE

½	CR4T005	1601.26	423.05
¾	CR4T007	937.78	247.76
1	CR4T010	606.18	160.15
1¼	CR4T012	279.68	73.89
1½	CR4T015	147.65	39.01
2	CR4T020	111.90	29.56

STAINLESS STEEL WELDOLETS ON SCH 40 PIPE

2½	CR4W025	106.31	28.09
3	CR4W030	72.27	19.09
4	CR4W040	36.84	9.73
5	CR4W050	29.28	7.73
6	CR4W060	20.29	5.36
8	CR4W080	11.73	3.10
10	CR4W100	7.45	1.97
12	CR4W120	5.24	1.39

CARBON STEEL WELDOLETS ON SCH 40 PIPE

2½	CS4W025	105.70	27.93
3	CS4W030	70.68	18.67
4	CS4W040	36.38	9.61
5	CS4W050	29.28	7.73
6	CS4W060	20.29	5.36
8	CS4W080	11.73	3.10
10	CS4W100	7.45	1.97
12	CS4W120	5.24	1.39

GALVANIZED IRON TEES ON SCH 40 PIPE

1	IR4T010	558.50	147.56
1¼	IR4T012	334.45	88.36
1½	IR4T015	248.97	65.78
2	IR4T020	146.00	38.57

7.3 Calibration Data: K-factors

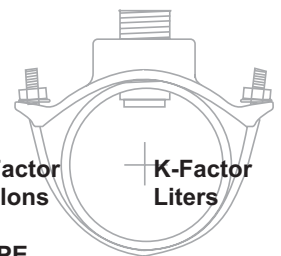
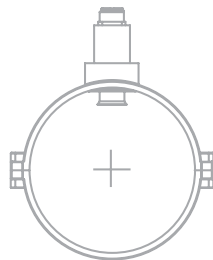
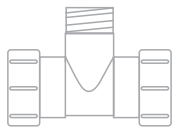

Polypropylene True Union Tees and Wafers
Polypropylene Clamp-on Saddles
PVDF True Union Tees and Wafers
PVC True Union Tees and Wafers

PIPE SIZE (Metric)	FITTING TYPE	K-Factor Gallons	K-Factor Liters
POLYPROPYLENE FITTINGS (DIN/ISO ,BS, ANSI)			
DN15	PPMT005	2192.73	579.32
DN20	PPMT007	1327.81	350.81
DN25	PPMT010	737.16	194.76
DN32	PPMT012	453.46	119.81
DN40	PPMT015	275.03	72.66
DN50	PPMT020	164.17	43.35
DN65	PPMT025	112.02	29.59
DN80	PPMT030	77.40	20.45
DN100	PPMT040	51.76	13.68
DN125	PPMT050	40.14	10.61
DN150	PPMT060	24.51	6.47
DN200	PPMT080	15.66	4.14

POLYPROPYLENE CLAMP-ON SADDLES ON SCH 80 PP PIPE			
10	PPS100	7.94	2.10
12	PPS120	5.71	1.51

POLYPROPYLENE CLAMP-ON SADDLES ON SCH 40 PP PIPE			
10	PPS100	7.43	1.96
12	PPS120	5.23	1.38

PVDF FITTINGS (DIN/ISO ,BS, ANSI)			
DN15	SFMT005	1946.49	514.26
DN20	SFMT007	1158.05	305.96
DN25	SFMT010	749.09	197.91
DN32	SFMT012	439.51	116.12
DN40	SFMT015	248.93	65.77
DN50	SFMT020	146.85	38.80
DN65	SFMT025	104.84	27.70
DN80	SFMT030	72.01	19.02
DN100	SFMT040	46.82	12.37
DN125	SFMT050	31.93	8.44
DN150	SFMT060	18.78	4.96
DN200	SFMT080	11.86	3.13

PVC FITTINGS (DIN/ISO ,BS, ANSI)			
DN15	PVMT005	2067.76	546.30
DN20	PVMT007	1136.61	300.29
DN25	PVMT010	716.52	189.31
DN32	PVMT012	446.07	117.85
DN40	PVMT015	278.83	73.67
DN50	PVMT020	159.36	42.10
DN65	PVMT025	110.11	29.09
DN80	PVMT030	73.92	19.53
DN100	PVMT040	47.86	12.64
DN125	PVMT050	36.18	9.56
DN150	PVMT060	21.56	5.70
DN200	PVMT080	13.81	3.65

Iron Saddles

PIPE SIZE (IN.)	FITTING TYPE	K-Factor Gallons	K-Factor Liters
SCH 80 IRON SADDLE ON SCH 80 PIPE			
2	IR8S020	194.85	51.48
2½	IR8S025	142.28	37.59
3	IR8S030	87.53	23.13
4	IR8S040	40.62	10.73
5	IR8S050	29.28	7.74
6	IR8S060	22.30	5.89
8	IR8S080	12.52	3.31
10	IR8S100	7.94	2.10
12	IR8S120	5.65	1.49

SCH 80 IRON SADDLE ON SCH 40 PIPE			
2	IR8S020	185.35	48.97
2½	IR8S025	127.47	33.68
3	IR8S030	76.62	20.24
4	IR8S040	40.23	10.63
5	IR8S050	27.32	7.22
6	IR8S060	19.71	5.21
8	IR8S080	11.61	3.07
10	IR8S100	7.36	1.94
12	IR8S120	5.18	1.37

Bronze and Copper Tees and Brazolets

PIPE SIZE (IN.)	FITTING TYPE	K-Factor Gallons	K-Factor Liters
BRONZE TEES ON SCH 40 PIPE			
1	BR4T010	582.34	153.86
1¼	BR4T012	330.54	87.33
1½	BR4T015	254.76	67.31
2	BR4T020	157.36	41.58

COPPER TEES FITTING ON COPPER PIPE SCH K			
½	CUKT005	2459.19	649.72
¾	CUKT007	1108.02	292.74
1	CUKT010	649.87	171.70
1¼	CUKT012	422.03	111.50
1½	CUKT015	281.43	74.35
2	CUKT020	136.02	35.94

COPPER TEES FITTING ON COPPER PIPE SCH L			
½	CUKT005	2406.30	635.75
¾	CUKT007	1174.77	310.37
1	CUKT010	672.28	177.62
1¼	CUKT012	402.84	106.43
1½	CUKT015	294.99	77.94
2	CUKT020	149.63	39.53

COPPER/BRONZE BRAZOLET ON SCH 40 PIPE			
2½	BR4B025	117.31	30.99
3	BR4B030	78.62	20.77
4	BR4B040	45.13	11.92
5	BR4B050	32.79	8.66
6	BR4B060	22.73	6.01
8	BR4B080	13.14	3.47
10	BR4B100	8.34	2.20
12	BR4B120	5.87	1.55

8.0 Calibration Menu

The K-factors published in this manual assume that the flow conditions in the pipe are ideal.

Many factors that affect the flow rate are beyond the control of the magmeter; variations in actual pipe dimensions, pipe smoothness, and other flow conditions will contribute to the total system error.

Performing a custom calibration with the magmeter in place will adjust the K-factor and can serve to compensate for installation conditions that may be less than ideal.

Select one of the calibration methods in this menu to achieve the most accurate measurement possible in a specific application.

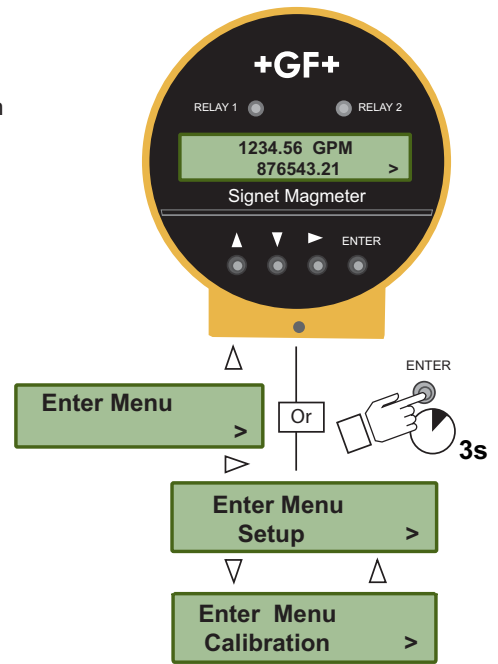
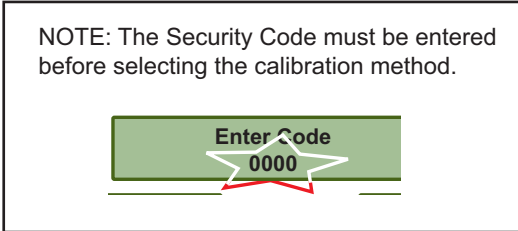

8.1 Volume method of calibration

Use the volume method of calibration if the fluid passing the magmeter can be measured by a volumetric method (as in a vessel of known volume, or by weight). It requires the ability to pump a known volume of water past the magmeter, and then input the volume into the 2551 program. It is most useful for small pipes and lower flow rates.

When performed properly, volumetric calibration is the most accurate method. For best results a five minute test period is recommended, and the test period should be no less than two minutes.

Press Enter To Start	At START, the 2551 begins counting the flow past the sensor.
Press Enter To Stop	At STOP, the 2551 stores the total flow accumulated since the START.
Enter Volume 000000. GPM	Enter the VOLUME that has been pumped past the sensor.
Value must be more than 0.0	This error message appears if volume entered or the accumulated flow is zero. Repeat the test after checking the system.
K-Factor Out of Range	This message appears if the new K-Factor is less than 0.0001 or greater than 999999. To correct the problem, perform the volumetric flow again, and be certain that the volume entered is accurate.
K-Factor 45.6789	Using the information from the VOLUME method, the 2551 will recalculate a new K-Factor. Press ENTER to accept the new value, or use the keypad to adjust the value.

8.2 Rate method of calibration

Use this method if the 2551 Magmeter must be calibrated to match a reference flow meter. This is the method most commonly used by monitoring agencies, and for large pipes where volumetric calibration is impractical. The accuracy of this calibration method is largely dependent on the accuracy of the reference meter and the proximity of the reference to the Signet 2551 Magmeter.

Set New Flowrate 45.6789	The flow rate shown is based on the existing calibration of the 2551. Use the keypad to modify the flow rate to match the reference meter. The 2551 will automatically calculate a new K-factor based on the new flow rate.
K-Factor Out of Range	This message appears if the new K-Factor is less than 0.0001 or greater than 999999. To correct the problem, reexamine the flow rate and make certain it is accurate.
K-Factor 56.7890	Using the information from the RATE MATCHING method, the 2551 will recalculate a new K-Factor. Press ENTER to accept the new value, or use the keypad to adjust the value.

9.0 Relay Menus

Magmeter models 3-2551-21 and 3-2551-22 have two dry contact relays (Relays 1 and 2) and one Solid State relay (Relay 3).

Any of these relays can be set to any of the operating modes listed below.

The setpoint values for HIGH, LOW and WINDOW modes can be set to negative values if required.

For example, a LOW alarm might be set to activate if the flow rate falls below -10 GPM.

Negative values are not available for relays in PULSE or TOTAL modes.

Off: If a relay is not used, it can be turned Off to prevent contact wear.



NOTE: The Security Code must be entered before modifying the relay menu.

Enter Code
0000

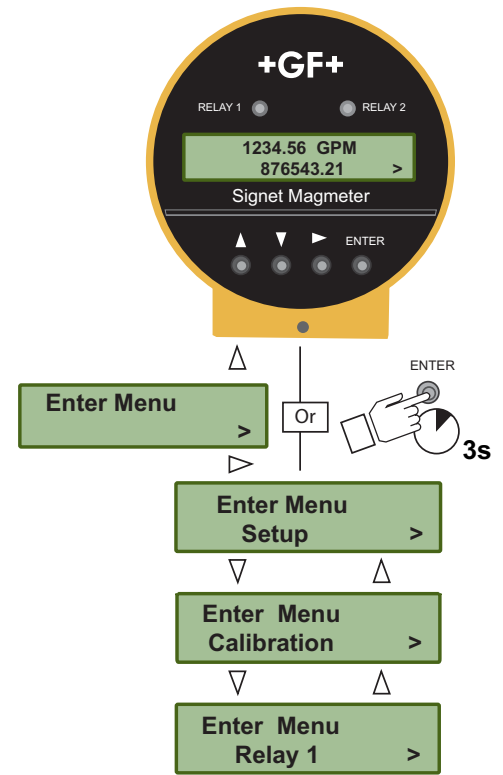

9.1 Pulse Relay mode

Program a relay to activate for a fixed period, for each volume of fluid that passes the sensor.

For example, program the relay to pulse once for 100 ms for every 3 gallons that pass by the sensor.

Relay 1 Mode
 Pulse >

Relay 1 Volume
 0.0000 Gal >

Relay 1 Width
 0.1 secs >

Relay Volume: Set the volume of fluid that the 2551 must measure before activating the relay for one pulse.

Pulse Width: Adjust the length of time the relay will remain activated. The pulse width setting is dependent on the type of external equipment being connected to the relay.

9.2 Total Relay mode

Program a relay to activate when the Resettable totalizer reaches a specific value. The maximum setting is 999999.

Application example: A filter must be replaced in a R.O. system every 10000 gallons. The service representative that installs a new filter sets relay 3 to Total mode, sets the setpoint at 10000 and resets the totalizer to 000000.00. When the totalizer is reset, the relay will be deactivated and the process begins anew.

Every time the Totalizer reaches 10000, the relay activates and lights a message indicator to remind the operator to contact the service representative to replace the filter.

Relay 1 Mode
 Total >

Relay 1 Set High
 000000 >

9.3 High, Low, or Window Relay modes

Program the relay to activate when the flow rate reaches a setpoint (High or Low) or when the flow rate moves outside of a prescribed range (Window).

Reverse Flow

The setpoint values for HIGH, LOW and WINDOW modes can be set to negative values if required. For example, a LOW alarm might be set to activate if the flow rate falls to -10 GPM.

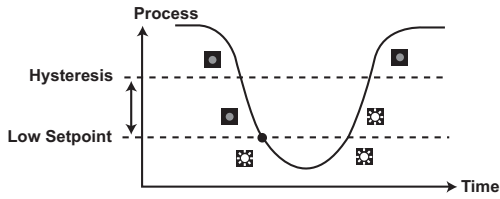

Relay behavior with LOW Setpoint

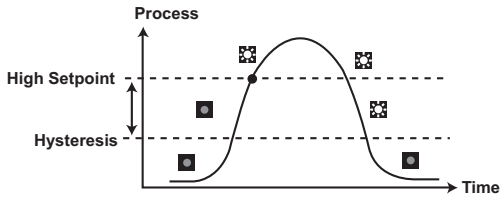

Relay behavior with HIGH Setpoint

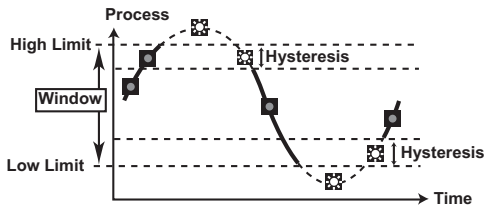

Relay behavior with WINDOW Setpoints

Relay activated 
Relay deactivated 

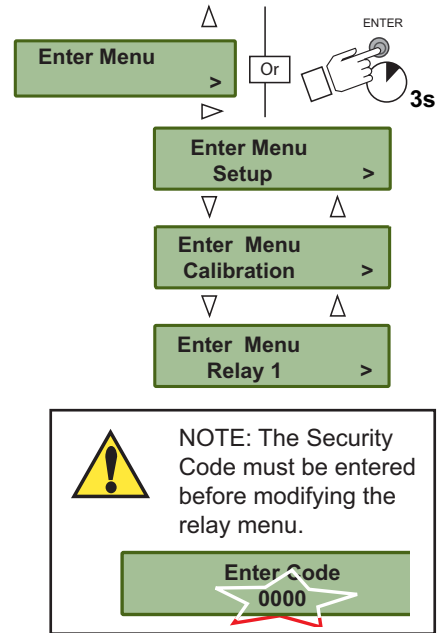

The values shown for each menu item represent the factory standard setting. All 2551 magmeters are packaged with these settings.

Set Low: Set the flow rate where a Low relay will be activated.

Relay 1 Mode Low >	Relay 1 Set Low 00.000 GPM >
	Relay 1 Hys 00.000 GPM >
	Relay 1 Delay 0.1 secs >

Set High: Set the flow rate where a High relay will be activated.

Relay 1 Mode High >	Relay 1 Set High 00.000 GPM >
	Relay 1 Hys 00.000 GPM >
	Relay 1 Delay 0.1 secs >

Hysteresis: Set a flow rate increment where the relay will be deactivated. The hysteresis setting serves to prevent relay "chatter" when the flow rate recovers from an alarm condition by requiring the low rate to move substantially within the setpoint.

Delay: Set a time period for the relay to wait after reaching the setpoint. This delay serves to prevent the relay "chatter" by allowing the flow rate time to move back within the setpoint.

Relay 1 Mode Window >	Relay 1 Set Low 00.000 GPM >
	Relay 1 Set High 00.000 GPM >
	Relay 1 Hys 00.000 GPM >
	Relay 1 Delay 0.1 secs >

The menu repeats for Relay 2 and Relay 3.

10.0 Test Menu

The Test menu provides a simple method to verify that the system is operating properly. Auxiliary power **MUST** be connected to the 2551 to activate the relays



Test Output 4.20 mA >
Test Relay 1 Open Closed >
Test Relay 2 Open Closed >
Test Relay 3 Open Closed >

Shown for 4-20 mA models Only

Use the keypad to enter any current output from 4.0 mA minimum to 22.1 mA maximum.

Shown for Relay models Only

Toggle any of these relays ON and OFF to verify that the system is operating properly.

Auxiliary power **MUST** be connected to the 2551 to test the relays.

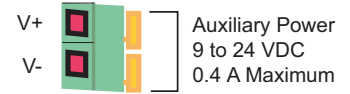

11.0 Options Menu

The Options Menu contains those features and settings that will normally be set one time and then seldom changed. These include language preference, decimal placement, Security Code assignment, etc.



Language English >
Security Code **** >
Contrast 2 >
Total Reset Lock On >
Noise Rejection 60 Hz >
Flow Decimal ****. ** >
Total Decimal *****. ** >
Separator ddd.d >
Output Mode Frequency >

Select from English, German, French or Spanish.

This Selection will be displayed at first power-up of a new magmeter.

Security Code can be set to any four digit number. Factory standard setting is 0000.

Set for best view after the magmeter is installed. Larger number means display appears darker.

Lock ON requires the Security Code before resetting the Resettable Totalizer. Lock OFF reset with no security code.

Filters out common 50 or 60 Hz electrical noise.

Set the maximum resolution for the FLOW RATE display by limiting the decimal to this point. The Flow Rate display will auto-scale from this resolution up to whole units.

Set the maximum resolution for the TOTALIZER display by limiting the decimal to this point. The Totalizer display will always show this resolution.

Select decimal point or comma for use in numeric displays.

For Frequency/Digital models only: Select Freq output, Freq ÷ 10 output, Mirror Relay 1 output or S³L Digital output.

The values shown for each menu item represent the factory standard setting. All 2551 magmeters are packaged with these settings.

11.1 Output Modes

In **FREQUENCY** output mode, the 2551 serves as a traditional flow sensor and provides an output pulse that is compatible with all Signet POWERED flow instruments. It is not compatible with the 5090 Self-Powered Flow Meter or the 8150-1 Battery-powered flow totalizer. The frequency output range is from 0 Hz to 1000 Hz.

The **FREQUENCY ÷ 10** output mode reduces the output frequency of the 2551 to a range that is useful for some programmable logic controllers (PLC). The frequency output range is from 0 Hz to 100 Hz. This shift does not affect the stated accuracy of the 2551 Magmeter's frequency output.

The **MIRROR RELAY 1** output mode allows 2551 Frequency/Digital models to use the Open Collector Output like a relay that can be programmed via the Relay 1 menu.

If the magmeter is equipped with relays, this mode will mirror the settings of Relay 1.

If the magmeter is not equipped with relays, this mode can still be selected and programmed via the Relay 1 menu.

The **S³L Digital** output mode switches the 2551 to the Signet serial data output called S³L (Signet Serial Sensor Link). In this mode the 2551 can be added to the serial bus of the Signet 8900 Multi-Parameter Controller.

12.0 Technical Information

12.1 Grounding

Precalibration conditioning: The magmeter may appear to be unstable immediately after installation. Allow the sensor to sit in a full pipe **for 24 hours** before beginning calibration and operation.

- Use a cable gland or a liquid tight connector to seal the cable ports from water intrusion.
- Use Teflon tape or a suitable sealant on cable ports.
- The 2551 magmeter must be carefully grounded to eliminate electrical noise that may interfere with the measurement.
- Grounding requirements will vary with each installation.
- The following recommendations should be applied in sequence until the interference is eliminated.

- ① The ground terminal on the outside of the yellow housing is connected internally to the grounding ring at the tip of the sensor. Connect a conductor (14 AWG/1.5 mm² wire recommended) from this terminal directly to Earth ground to prevent electrical noise from interfering with the magmeter signal.

If the interference persists, apply step #2:

- ② Connect grounding rings, metal clamps or grounding electrodes to the pipe immediately upstream and downstream of the magmeter sensor location. These devices must be in contact with the fluid.

If the interference persists, apply step #3:

- ③ The shield from the output cable must be terminated at the remote instrument ONLY. This shield must not be connected at both ends!

If the interference persists, apply step #4:

- ④ Connect an additional wire (minimum AWG 14/1.5 mm²) from the remote instrument ground to the magmeter ground terminal.

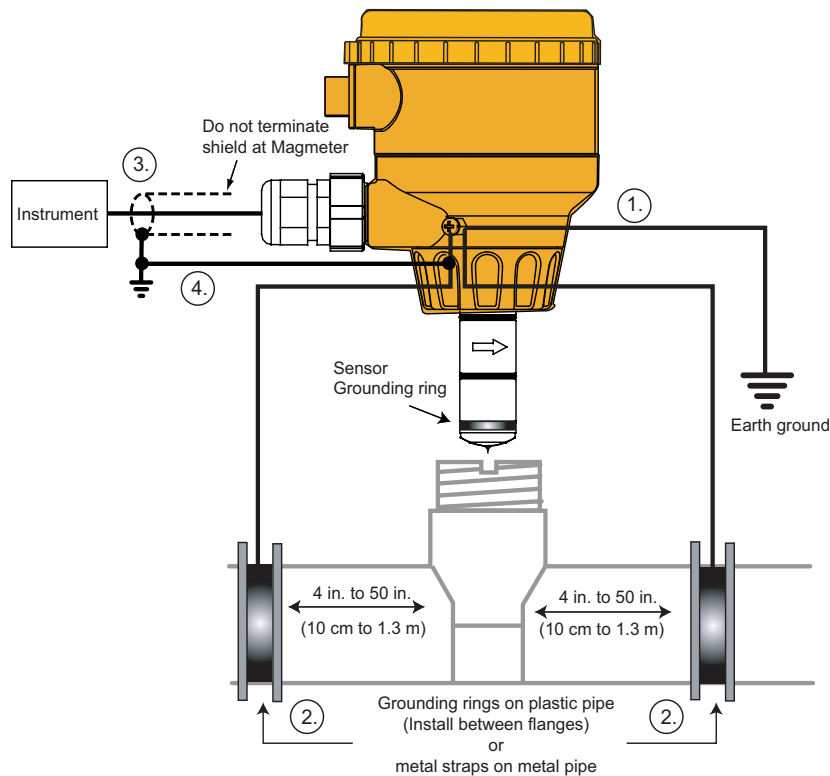

12.2 Maintenance

The 2551 Magmeter requires very little maintenance. There are no user-serviceable components in the magmeter.

- If the fluid contains deposits and solids that may coat the electrodes, a regular cleaning regimen is recommended.
- Do not use abrasive materials on the metal electrodes. Clean with soft cloth and mild detergent only.
- Use a cotton swab and mild detergent to remove deposits on the metal electrodes.

Environmental Recommendations:

- When used properly, this product presents no inherent danger to the environment.
- Please follow local ordinance when disposing of this or any product with electronic components.

12.3 Troubleshooting

Symptom	Possible Cause	Solution
<ul style="list-style-type: none"> Output is erratic and unstable. 	<ul style="list-style-type: none"> Magmeter installed too close to upstream obstruction. Magmeter located in area exposed to air bubbles/pockets. Magmeter is installed in pipe backwards. Electrical noise is interfering with the measurement. Electrodes are coated with deposits or chemical oxide layers. 	<ul style="list-style-type: none"> Relocate the magmeter to have straight uninterrupted pipe upstream of the sensor for at least 10 x the pipe diameter. Eliminate air bubbles in the pipe. Remove the magmeter and reinstall with the flow direction arrow on the sensor body pointed DOWNSTREAM. Review the grounding of the magmeter and the pipe. Install adequate Earth ground to allow the magmeter to operate properly.
<ul style="list-style-type: none"> Output is not 0 when flow is stopped. 	<ul style="list-style-type: none"> Electrodes not adequately conditioned in fluid. Fluid is moving inside the pipe. 	<ul style="list-style-type: none"> Allow the sensor to sit in full pipe for 24 hours then restart. Increase the Low Flow Cutoff. (section 7.0)
<ul style="list-style-type: none"> No 4-20 mA output. 	<ul style="list-style-type: none"> Loop power not connected correctly. 	<ul style="list-style-type: none"> Connect 24 VDC \pm10% connected to loop terminals 1 and 3.
<ul style="list-style-type: none"> 4-20 mA current output is incorrect. 	<ul style="list-style-type: none"> 4-20 mA is not scaled properly. 	<ul style="list-style-type: none"> Check and reset in the Setup Menu.
<ul style="list-style-type: none"> No Frequency output. No S³L output. 	<ul style="list-style-type: none"> 2551 is wrong model. Incorrect setting in Options Menu. Wiring is not correct. Frequency input to other manufacturer's flow instrument does not have pull-up resistor. 	<ul style="list-style-type: none"> Frequency/S³L model: 3-2551-21 (w/rlys) or -41 (w/o rlys) Select Frequency in the Options menu. Check wiring, make corrections. Install 10kΩ resistor. (section 5.1)
<ul style="list-style-type: none"> No flow rate, current output is 22 mA. 	<ul style="list-style-type: none"> The fluid is too clean for magmeter. Electronic component failure. 	<ul style="list-style-type: none"> Unsuitable application for magmeter. Return 2551 to factory.
<ul style="list-style-type: none"> Blank display, no backlighting, no relay LEDS, but external equipment using output signal is still working. 	<ul style="list-style-type: none"> 2551 AUX power is not connected. 	<ul style="list-style-type: none"> Connect AUX power (section 5.5) (9 to 24 VDC, 0.4 A max.)
<ul style="list-style-type: none"> Error Message: "Error Not Saved" 	<ul style="list-style-type: none"> Main power is below specification 	<ul style="list-style-type: none"> Correct the main power deficiency

Troubleshooting with the RED and BLUE lights

No Lights:

The power is off or the sensor is not connected

Solid Blue:

The power is on but there is no flow in the pipe.

Blinking Blue:

Normal operation, blink rate is proportional to the flow rate.

Alternating Red-Blue:

Empty pipe indication (electrodes are not wet.)

Blinking Red:

System errors (Electrical noise interference)

Solid Red:

Instrument error (defective electronic component)

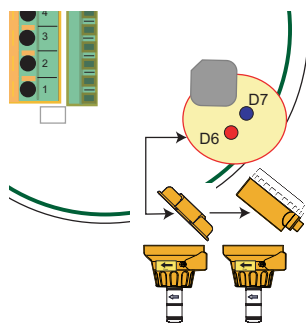

Reverse flow:

- Frequency out cannot distinguish reverse flow from forward flow. The output will be the absolute value.
- Digital (S³L) output: Reverse flow results in 0 flow rate displayed on 8900
- 4-20 mA output can be spanned into negative flow range using the custom setup tool. (example: 4-20 mA = -100 to +100 GPM)

Empty Pipe Detection

- Frequency output will be locked to 0 Hz if electrodes are not wet.
- Digital (S³L) output will be locked to 0 if electrodes are not wet.
- 4-20 mA will be locked to 4 mA if electrodes are not wet.
- Blue and Red LED indicators on the magmeter circuit will blink alternately if the electrodes are not wet.

13.0 Ordering Information

Sensor Part No.	
3-2551	
Sensor Body (Transducer) and electrodes/grounding ring materials - Choose one	
-P	Polypropylene and 316L SS
-T	PVDF and Titanium
-V	PVDF and Hastelloy C
-W	PVDF and 316L SS
Pipe size - Choose one	
0	DN15 to DN100 (1/2 to 4 in.)
1	DN125 to DN200 (5 to 8 in.)
2	DN250 to DN300 (10 to 12 in.)
Display Options - Choose One	
-2	With Display, two SPDT relays, one solid state relay
-4	With Display, no relays
Output options - Choose One	
1	Open Collector Frequency out or Digital (S ³ L) out
2	4 to 20 mA output
3-2551	-P 0 -2 2 Example Part Number

Mfr. Part Number	Code	Mfr. Part Number	Code
3-2551-P0-21	159 001 267	3-2551-V0-21	159 001 269
3-2551-P0-22	159 001 273	3-2551-V0-22	159 001 275
3-2551-P0-41	159 001 261	3-2551-V0-41	159 001 263
3-2551-P0-42	159 001 279	3-2551-V0-42	159 001 281
3-2551-P1-21	159 001 268	3-2551-V1-21	159 001 270
3-2551-P1-22	159 001 274	3-2551-V1-22	159 001 276
3-2551-P1-41	159 001 262	3-2551-V1-41	159 001 264
3-2551-P1-42	159 001 280	3-2551-V1-42	159 001 282
3-2551-P2-21	159 001 435	3-2551-V2-21	159 001 456
3-2551-P2-22	159 001 438	3-2551-V2-22	159 001 457
3-2551-P2-41	159 001 432	3-2551-V2-41	159 001 462
3-2551-P2-42	159 001 441	3-2551-V2-42	159 001 463
3-2551-T0-21	159 001 436	3-2551-W0-21	159 001 271
3-2551-T0-22	159 001 439	3-2551-W0-22	159 001 277
3-2551-T0-41	159 001 433	3-2551-W0-41	159 001 265
3-2551-T0-42	159 001 442	3-2551-W0-42	159 001 283
3-2551-T1-21	159 001 437	3-2551-W1-21	159 001 272
3-2551-T1-22	159 001 440	3-2551-W1-22	159 001 278
3-2551-T1-41	159 001 434	3-2551-W1-41	159 001 266
3-2551-T1-42	159 001 443	3-2551-W1-42	159 001 284
3-2551-T2-21	159 001 454	3-2551-W2-21	159 001 458
3-2551-T2-22	159 001 455	3-2551-W2-22	159 001 459
3-2551-T2-41	159 001 460	3-2551-W2-41	159 001 464
3-2551-T2-42	159 001 461	3-2551-W2-42	159 001 465

Replacement parts

Mfr. Part No.	Code	Description
1220-0021	198 801 186	O-ring, FPM (Viton [®])
1224-0021	198 820 006	O-ring, EPDM
1228-0021	198 820 007	O-ring, FFPDM (Kalrez [®])
3-8551.521	159 001 378	Clear plastic cap for display
3-8050.396	159 000 617	RC Filter kit (for relay protection)



George Fischer Signet Inc., 3401 Aerojet Avenue, El Monte, CA 91731-2882 U.S.A. • Tel. (626) 571-2770 • Fax (626) 573-2057
 For Worldwide Sales and Service, visit our website: www.gfsignet.com • Or call (in the U.S.): (800) 854-4090

