



4-3000.090

rev. F 8/05 English

WARNING! SAFETY INSTRUCTIONS



1. Depressurize and vent system prior to installation/removal.
2. Confirm chemical compatibility before use.
3. Do not exceed maximum temperature/pressure specifications.
4. Wear safety goggles or faceshield during installation/service.
5. Do not alter product construction.



Page	Contents
1.	Description
1.	Specifications
2.	Installation
3.	Wiring
4-6.	K-Factors
7.	Maintenance and Repair
8.	Ordering Information

1. Description of 3000 Irrigation Flow Sensor

The Signet 3000-5 Irrigation Flow Sensor offers a reliable, accurate means for measuring water flow in irrigation piping systems. An electromagnetic signal is transmitted from the rotor tip directly to the pick-up within the sensor.

- No recalibration required after routine maintenance
- Can be mounted at any angle for versatile installation
- Innovative rotor design, one moving part, snap-on rotor replacement (no special tools required)

2. Specifications

General

- Typical Flow Rates:

6"	88 to 1,761 gpm
8"	157 to 3,132 gpm
10"	245 to 4,893 gpm
12"	352 to 7,046 gpm
- Operating Velocity Range: 1 to 20 ft/s
- Repeatability: $\pm 0.5\%$ of max range
- Accuracy: $\pm 2\%$ of reading (under reference conditions)
- Pipe Size Range: 6, 8, 10, and 12 in. (larger sizes with custom K-Factors)
- Cable Length: 100 ft. max. (customer supplied)
- Cable Type: 2-conductor shielded twisted pair, 14-22 AWG
- Rotor Diameter: 5 in.

Wetted Materials:

- Sensor Body: PC/PBT Alloy
- Rotor (propeller) Assembly: PC/PBT Alloy and Acetal
- Sensor Flange: A-36 Cold Roll Steel with Galvanized Coating
- Sensor Gasket: Poron Cellular Urethane
- Rotor Bearing and Shaft: Ceramic
- Rotor Face Seal: 316 SS

Electrical:

- Supply Voltage: 3.5 to 27 VDC
- Supply Current:
 - <20 μ A with sensor powered with 3.5-5 VDC
 - <3mA with sensor powered with 5-27 VDC
- Signal Output: Open collector transistor, sink, max. pullup voltage 27 VDC (transistor normally off)
- Max. Open-Collector Current Out: 20 mA
- Output Pulse Width: 3 msec. nominal

Fluid Conditions:

Agriculture Sensor Maximum Pressure/Temperature Ratings:

- 150 psi max @ 68°F
- 32 psi max @ 140°F

Quality Standards:

- Manufactured under ISO 9001 and 14001
- Conforms with EN55082-1

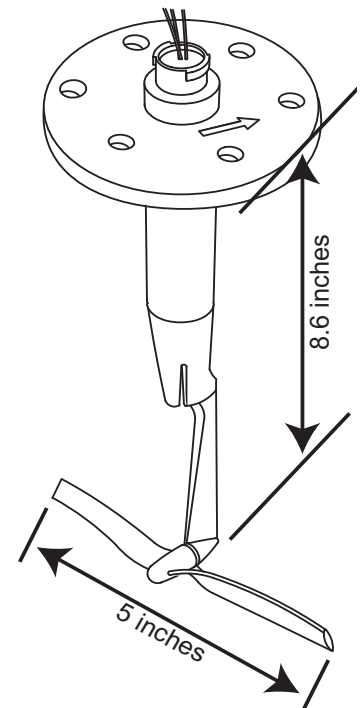

3. Installation

3.1 Location

- Select a location where the pipe will always be full.
- The pipe must be straight and uninterrupted for at least ten pipe diameters before the sensor. Five diameters are acceptable after a simple 90 degree elbow. The K-factor must be adjusted according to the charts in section 4 of this manual.

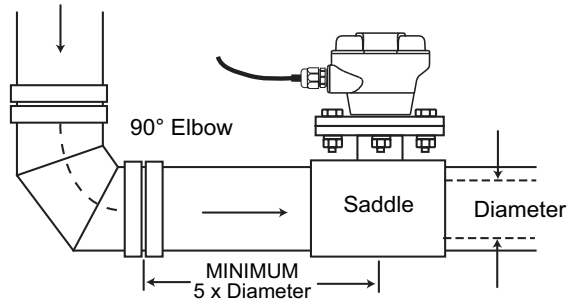

3.2 Saddle Installation

1. Drill a 2.5 inch hole in the pipe. Deburr the cut edges to prevent damage to the saddle gasket.
2. Measure and record the inside diameter (ID) of the pipe as illustrated.
3. Place the flanged fitting half of the strap-on saddle over the hole. Ensure that the alignment hole on the upper saddle flange is pointing **downstream**.
4. Place the lower half of saddle onto pipe and tighten the bolts to no more than 65 foot-pounds.

NOTE: Installation fittings may be fabricated using the dimensional drawings below. The flange height is critical to the accuracy of the measurement!

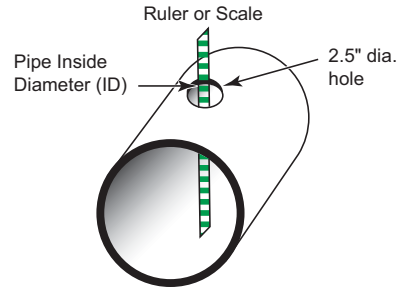

3.3 Sensor Installation

1. Install sensor into pipe with alignment pin downstream.
2. **Place the base plate for the outer cover over the sensor flange.**
2. Bolt the assembly securely with the hardware provided.
3. Install the conduit base gasket onto the top of the sensor.
4. Position the conduit base over the top of the sensor and thread the sensor wires through the conduit base.
5. Press the conduit base down on the top of the sensor tube aligning the cutout keys and press down until it seats.
6. Turn the conduit base 1/4-turn clockwise to secure it to the sensor.

Note: The conduit base can be aligned in four directions.

7. Thread sensor wires through the locking ring. Insert locking ring into the conduit base, aligning it so that the square tab is close to the wire ports.

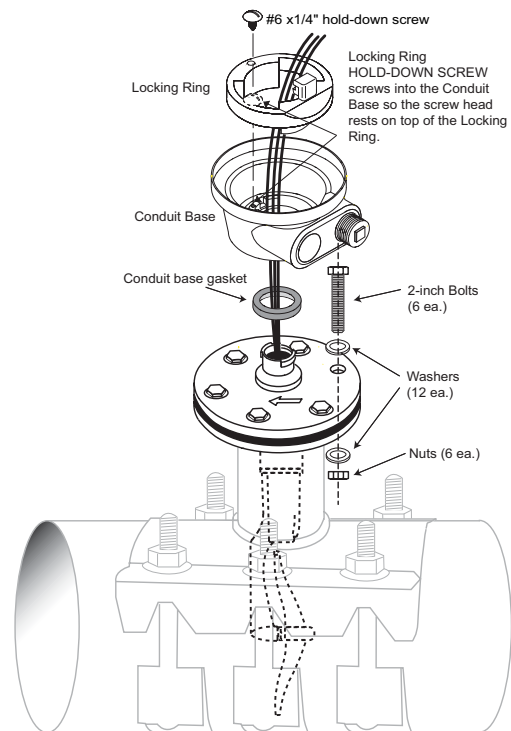
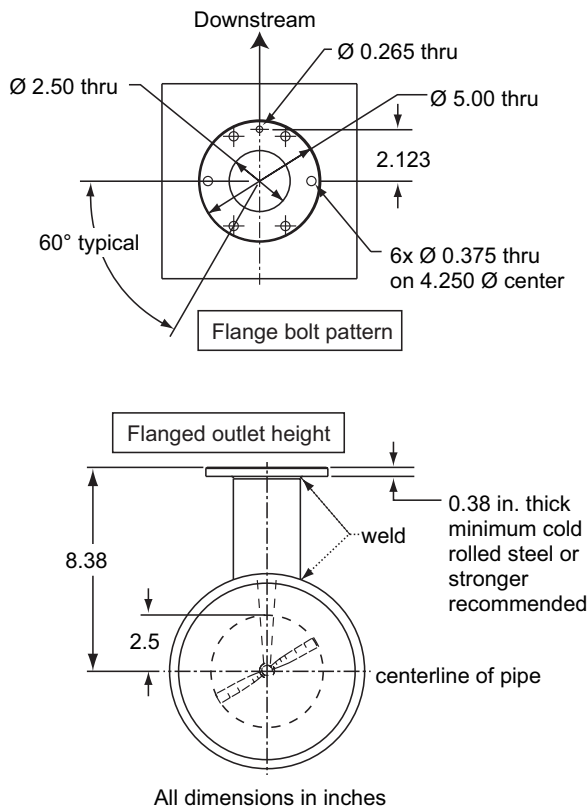
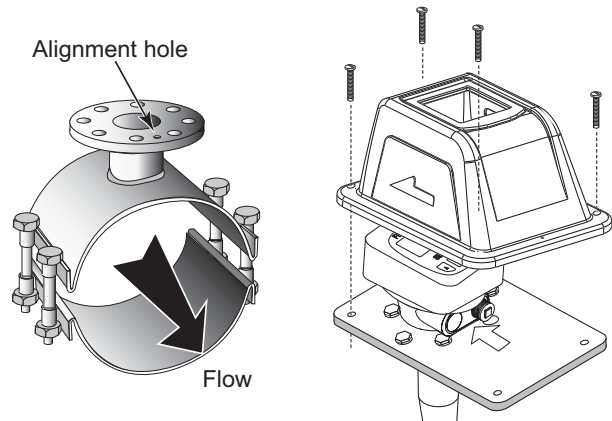

4. Wiring

Install the Signet 8150 Totalizer or the Signet 8550 Transmitter by connecting the sensor wires to the terminals as shown, then secure the instrument onto the base with a quarter-turn. The totalizer can be positioned in any quadrant for best viewing. The instrument may be mounted up to 100 ft. away from the pipe. Use the 3111 Terminal cover to extend the cable. Use 14-22 AWG conductors in a twisted pair.

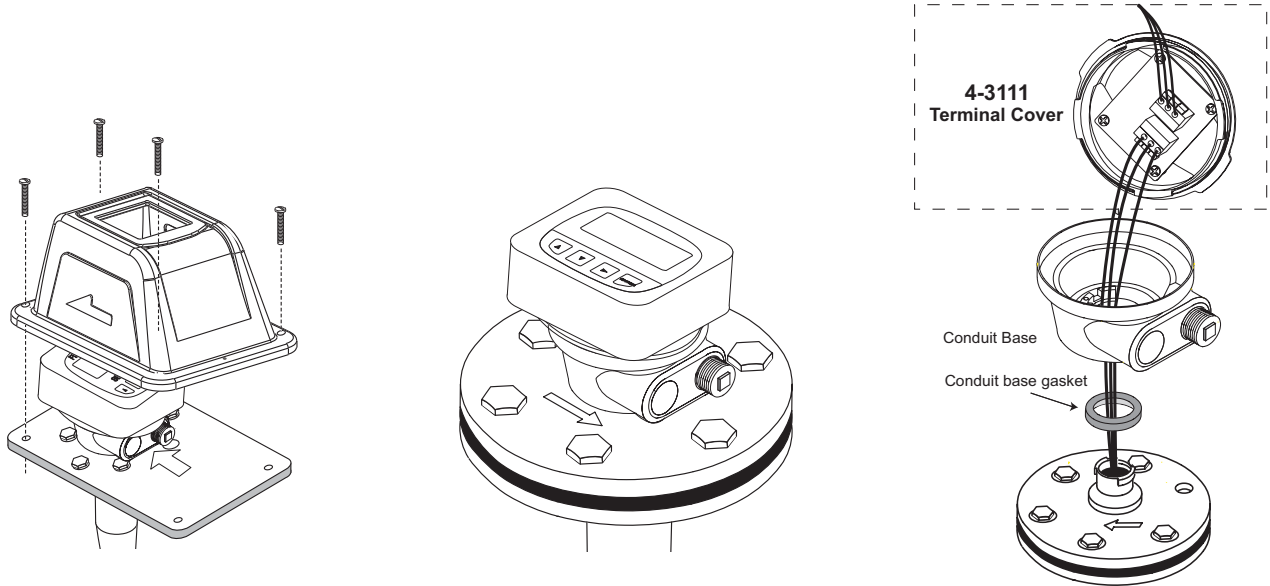

8150
Terminals

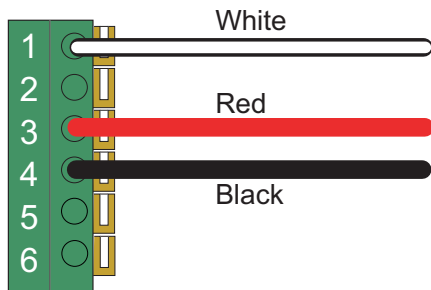

8550
Terminals

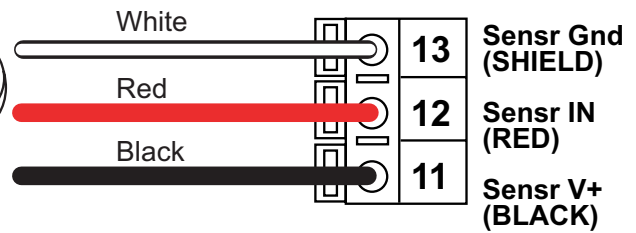

4.1 Remote Reset for Totalizer

The Signet 8150 Totalizer features a remote reset for the resettable totalizers. To access the terminals on the back of the totalizer, use the cable port and replace the black plug with a water-tight cable gland or conduit connection. The reset switch may be located up to 100 ft. from the totalizer.

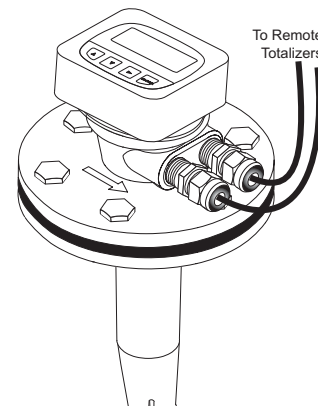
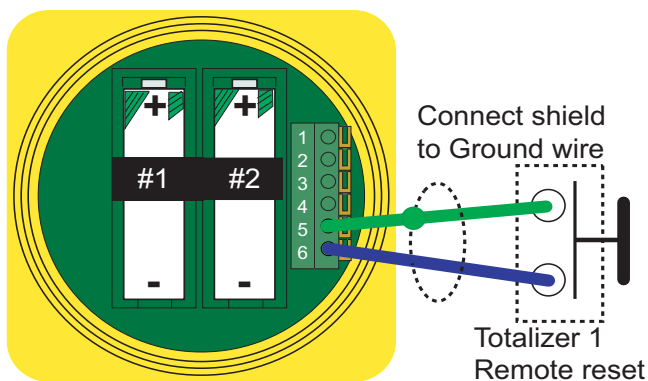

5. K-Factors

K-factors are calibration constants, defined as the number of pulses generated by the rotor for each measure (gallon, acre-inch, etc.) of water that passes by the sensor. The following tables provide the K-factor for pipe sizes from 5.5 in. diameter to 12.6 inches diameter.

After selecting the value that matches the installation, it must be entered into the program of the Signet 8150 Totalizer. This information enables the totalizer to correctly interpret the pulses coming from the AgRotor to display the flow rate and total flow volume. The instruction manual supplied with the Signet 8150 SC Totalizer includes complete information for using the K-factor.

How to Select Your K-Factor

1. Locate the column in the following tables that represents the inside diameter (ID) of your pipe.
2. Measure the distance (in inches) from the nearest elbow upstream of the sensor.
3. Find where the **ID** column and **Distance From Elbow** row intersect. This is your K-Factor setting.

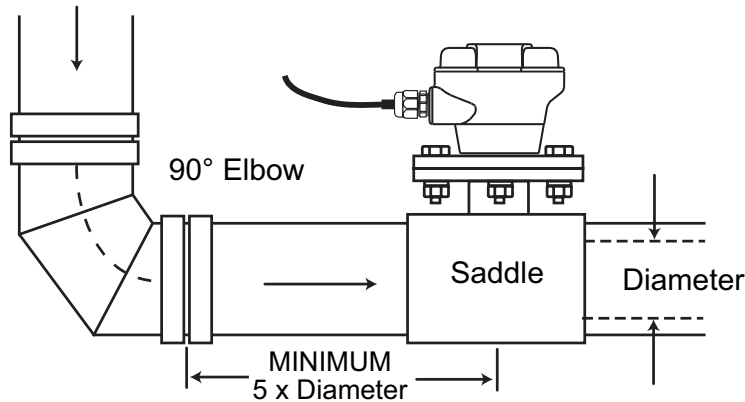

K-Factors for Sensor in 6 inch Pipe Downstream from a 90 degree elbow (mitered or smooth)

Pipe ID distance from elbow (inches)	5.5	5.6	5.7	5.8	5.9	6	6.065 Sched 40	6.1	6.2	6.3	6.4	6.5
30	3.135	3.045	2.955	2.865	2.775	2.685	2.627	2.595	2.505	2.415	2.326	2.236
40	3.210	3.118	3.026	2.934	2.841	2.749	2.689	2.657	2.564	2.472	2.380	2.288
50	3.272	3.178	3.084	2.990	2.896	2.802	2.740	2.707	2.613	2.519	2.425	2.331
60	3.321	3.226	3.130	3.035	2.940	2.844	2.782	2.749	2.654	2.558	2.463	2.367
70	3.361	3.264	3.168	3.072	2.975	2.879	2.816	2.783	2.686	2.590	2.494	2.398
80	3.392	3.295	3.198	3.101	3.004	2.907	2.844	2.810	2.713	2.616	2.519	2.422
90	3.416	3.319	3.221	3.124	3.027	2.929	2.866	2.832	2.735	2.637	2.540	2.443
100	3.435	3.337	3.240	3.142	3.045	2.947	2.884	2.849	2.752	2.654	2.557	2.459
110	3.449	3.352	3.254	3.156	3.059	2.961	2.897	2.863	2.766	2.668	2.570	2.472
120	3.461	3.363	3.265	3.167	3.070	2.972	2.908	2.874	2.776	2.679	2.581	2.483
130	3.469	3.371	3.274	3.176	3.078	2.980	2.917	2.883	2.785	2.687	2.589	2.492
140	3.476	3.378	3.280	3.182	3.085	2.987	2.923	2.889	2.791	2.694	2.596	2.498
150	3.481	3.383	3.285	3.188	3.090	2.992	2.929	2.894	2.797	2.699	2.601	2.504
160	3.485	3.387	3.289	3.192	3.094	2.996	2.933	2.899	2.801	2.703	2.606	2.508
170	3.489	3.391	3.293	3.195	3.098	3.000	2.936	2.902	2.804	2.707	2.609	2.511
180	3.492	3.395	3.297	3.199	3.101	3.003	2.940	2.905	2.808	2.710	2.612	2.514
190	3.496	3.398	3.300	3.202	3.104	3.006	2.943	2.908	2.810	2.712	2.614	2.516
200	3.502	3.403	3.305	3.207	3.108	3.010	2.946	2.912	2.813	2.715	2.617	2.518
210	3.508	3.409	3.310	3.212	3.113	3.014	2.950	2.915	2.817	2.718	2.619	2.521
220	3.508	3.409	3.310	3.212	3.113	3.014	2.950	2.915	2.817	2.718	2.619	2.521
230	3.508	3.409	3.310	3.212	3.113	3.014	2.950	2.915	2.817	2.718	2.619	2.521
240	3.508	3.409	3.310	3.212	3.113	3.014	2.950	2.915	2.817	2.718	2.619	2.521

K-Factors for Sensor in 8 inch Pipe Downstream from a 90 degree elbow (mitered or smooth)

ID(in)	7.5	7.6	7.7	7.8	7.9	7.961	8	8.1	8.2	8.3	8.4	8.5
distance from elbow (inches)	K factors (pulses per US gallon)						Sched 40					
40	1.745	1.704	1.664	1.623	1.583	1.558	1.542	1.501	1.461	1.420	1.379	1.339
50	1.777	1.735	1.694	1.652	1.611	1.586	1.570	1.528	1.487	1.445	1.404	1.362
60	1.804	1.762	1.720	1.678	1.636	1.610	1.593	1.551	1.509	1.467	1.425	1.383
70	1.827	1.784	1.742	1.699	1.657	1.631	1.614	1.571	1.529	1.486	1.443	1.401
80	1.847	1.804	1.761	1.718	1.675	1.648	1.632	1.588	1.545	1.502	1.459	1.416
90	1.863	1.820	1.777	1.733	1.690	1.663	1.647	1.603	1.560	1.517	1.473	1.430
100	1.877	1.834	1.790	1.747	1.703	1.676	1.659	1.616	1.572	1.529	1.485	1.441
110	1.889	1.845	1.801	1.758	1.714	1.687	1.670	1.626	1.583	1.539	1.495	1.451
120	1.899	1.855	1.811	1.767	1.723	1.696	1.679	1.635	1.592	1.548	1.504	1.460
130	1.907	1.863	1.819	1.775	1.731	1.704	1.687	1.643	1.599	1.555	1.511	1.467
140	1.913	1.869	1.825	1.781	1.737	1.711	1.693	1.649	1.605	1.561	1.517	1.473
150	1.919	1.875	1.831	1.787	1.743	1.716	1.699	1.655	1.611	1.567	1.523	1.479
160	1.923	1.879	1.835	1.791	1.747	1.720	1.703	1.659	1.615	1.571	1.527	1.483
170	1.927	1.883	1.839	1.795	1.751	1.724	1.707	1.663	1.619	1.575	1.531	1.487
180	1.930	1.886	1.842	1.798	1.754	1.727	1.710	1.666	1.622	1.578	1.534	1.490
190	1.932	1.888	1.844	1.800	1.756	1.730	1.712	1.668	1.624	1.580	1.536	1.492
200	1.935	1.891	1.847	1.803	1.759	1.732	1.715	1.671	1.627	1.583	1.539	1.495
210	1.936	1.892	1.848	1.804	1.760	1.734	1.716	1.672	1.628	1.584	1.540	1.496
220	1.938	1.894	1.850	1.806	1.762	1.735	1.718	1.674	1.630	1.586	1.542	1.498
230	1.940	1.896	1.852	1.808	1.763	1.737	1.719	1.675	1.631	1.587	1.543	1.499
240	1.941	1.897	1.853	1.809	1.765	1.738	1.721	1.677	1.633	1.589	1.545	1.500
250	1.943	1.899	1.855	1.810	1.766	1.739	1.722	1.678	1.634	1.590	1.546	1.502
260	1.945	1.901	1.856	1.812	1.768	1.741	1.724	1.679	1.635	1.591	1.547	1.502
270	1.947	1.903	1.858	1.814	1.770	1.743	1.725	1.681	1.636	1.592	1.548	1.503
280	1.950	1.905	1.861	1.816	1.772	1.744	1.727	1.683	1.638	1.593	1.549	1.504
290	1.953	1.908	1.864	1.819	1.774	1.747	1.729	1.684	1.640	1.595	1.550	1.505
300	1.957	1.912	1.867	1.822	1.777	1.749	1.732	1.687	1.642	1.597	1.552	1.507

K-Factors for Sensor in 10 inch Pipe Downstream from a 90 degree elbow (mitered or smooth)

ID(in)	9.5	9.6	9.7	9.8	9.9	10.02	10.1	10.2	10.3	10.4	10.5	11
distance from elbow (inches)	K factors (pulses per US gallon)						Sched 40					
50	1.088	1.067	1.047	1.026	1.005	0.981	0.964	0.944	0.923	0.903	0.882	0.779
60	1.109	1.088	1.067	1.046	1.025	1.000	0.983	0.962	0.941	0.920	0.899	0.794
70	1.128	1.107	1.085	1.064	1.042	1.017	1.000	0.978	0.957	0.935	0.914	0.807
80	1.145	1.123	1.101	1.079	1.058	1.032	1.014	0.993	0.971	0.949	0.927	0.819
90	1.159	1.137	1.115	1.093	1.071	1.045	1.027	1.005	0.983	0.961	0.940	0.830
100	1.172	1.150	1.128	1.106	1.083	1.057	1.039	1.017	0.995	0.972	0.950	0.839
110	1.184	1.161	1.139	1.117	1.094	1.067	1.049	1.027	1.005	0.982	0.960	0.848
120	1.194	1.171	1.149	1.126	1.104	1.077	1.059	1.036	1.014	0.991	0.968	0.856
130	1.203	1.180	1.157	1.135	1.112	1.085	1.067	1.044	1.021	0.999	0.976	0.863
140	1.211	1.188	1.165	1.142	1.120	1.092	1.074	1.051	1.028	1.006	0.983	0.869
150	1.217	1.195	1.172	1.149	1.126	1.099	1.080	1.058	1.035	1.012	0.989	0.875
160	1.224	1.201	1.178	1.155	1.132	1.104	1.086	1.063	1.040	1.017	0.995	0.880
170	1.229	1.206	1.183	1.160	1.137	1.110	1.091	1.068	1.045	1.022	0.999	0.885
180	1.234	1.211	1.188	1.165	1.142	1.114	1.096	1.073	1.050	1.027	1.004	0.889
190	1.238	1.215	1.192	1.169	1.146	1.118	1.100	1.077	1.054	1.031	1.008	0.893
200	1.241	1.218	1.195	1.172	1.149	1.122	1.103	1.080	1.057	1.034	1.011	0.896
210	1.244	1.221	1.198	1.175	1.152	1.125	1.106	1.083	1.060	1.037	1.014	0.899
220	1.247	1.224	1.201	1.178	1.155	1.127	1.109	1.086	1.063	1.040	1.017	0.902
230	1.249	1.226	1.203	1.180	1.157	1.130	1.111	1.088	1.065	1.042	1.019	0.904
240	1.251	1.228	1.205	1.182	1.159	1.131	1.113	1.090	1.067	1.044	1.021	0.906
250	1.252	1.229	1.206	1.184	1.161	1.133	1.115	1.092	1.069	1.046	1.023	0.908
260	1.254	1.231	1.208	1.185	1.162	1.134	1.116	1.093	1.070	1.047	1.024	0.909
270	1.254	1.232	1.209	1.186	1.163	1.135	1.117	1.094	1.071	1.048	1.025	0.911
280	1.255	1.232	1.209	1.186	1.164	1.136	1.118	1.095	1.072	1.049	1.026	0.912
290	1.256	1.233	1.210	1.187	1.164	1.137	1.119	1.096	1.073	1.050	1.027	0.913
300	1.256	1.233	1.210	1.188	1.165	1.137	1.119	1.096	1.073	1.051	1.028	0.913

K-Factors for Sensor in 12 inch Pipe Downstream from a 90 degree elbow (mitered or smooth)

ID(in) distance from elbow (inches)	11.5	11.6	11.7	11.8	11.9	12 Sched 40	12.1	12.2	12.3	12.4	12.5	12.6
	K factors (pulses per US gallon)											
60	0.791	0.778	0.765	0.753	0.740	0.727	0.714	0.702	0.689	0.676	0.663	0.651
70	0.803	0.790	0.777	0.764	0.751	0.738	0.725	0.712	0.699	0.686	0.673	0.660
80	0.814	0.801	0.788	0.775	0.762	0.748	0.735	0.722	0.709	0.696	0.683	0.669
90	0.824	0.811	0.797	0.784	0.771	0.758	0.744	0.731	0.718	0.704	0.691	0.678
100	0.833	0.820	0.806	0.793	0.779	0.766	0.752	0.739	0.725	0.712	0.699	0.685
110	0.841	0.828	0.814	0.800	0.787	0.773	0.760	0.746	0.733	0.719	0.705	0.692
120	0.849	0.835	0.821	0.807	0.794	0.780	0.766	0.753	0.739	0.725	0.712	0.698
130	0.855	0.841	0.828	0.814	0.800	0.786	0.772	0.759	0.745	0.731	0.717	0.704
140	0.861	0.847	0.833	0.820	0.806	0.792	0.778	0.764	0.750	0.736	0.723	0.709
150	0.866	0.853	0.839	0.825	0.811	0.797	0.783	0.769	0.755	0.741	0.727	0.713
160	0.871	0.857	0.843	0.829	0.815	0.801	0.787	0.774	0.760	0.746	0.732	0.718
170	0.876	0.862	0.848	0.834	0.820	0.806	0.792	0.778	0.764	0.750	0.736	0.722
180	0.880	0.866	0.851	0.837	0.823	0.809	0.795	0.781	0.767	0.753	0.739	0.725
190	0.883	0.869	0.855	0.841	0.827	0.813	0.799	0.785	0.770	0.756	0.742	0.728
200	0.886	0.872	0.858	0.844	0.830	0.816	0.802	0.788	0.773	0.759	0.745	0.731
210	0.889	0.875	0.861	0.847	0.833	0.819	0.804	0.790	0.776	0.762	0.748	0.734
220	0.892	0.878	0.863	0.849	0.835	0.821	0.807	0.793	0.779	0.764	0.750	0.736
230	0.894	0.880	0.866	0.852	0.837	0.823	0.809	0.795	0.781	0.767	0.753	0.738
240	0.896	0.882	0.868	0.854	0.839	0.825	0.811	0.797	0.783	0.769	0.754	0.740
250	0.898	0.884	0.869	0.855	0.841	0.827	0.813	0.799	0.785	0.770	0.756	0.742
260	0.899	0.885	0.871	0.857	0.843	0.829	0.814	0.800	0.786	0.772	0.758	0.744
270	0.901	0.887	0.872	0.858	0.844	0.830	0.816	0.802	0.788	0.773	0.759	0.745
280	0.902	0.888	0.874	0.859	0.845	0.831	0.817	0.803	0.789	0.775	0.761	0.746
290	0.903	0.889	0.875	0.860	0.846	0.832	0.818	0.804	0.790	0.776	0.762	0.748
300	0.904	0.890	0.875	0.861	0.847	0.833	0.819	0.805	0.791	0.777	0.763	0.749
310	0.904	0.890	0.876	0.862	0.848	0.834	0.820	0.806	0.792	0.778	0.763	0.749
320	0.905	0.891	0.877	0.863	0.849	0.835	0.820	0.806	0.792	0.778	0.764	0.750
330	0.905	0.891	0.877	0.863	0.849	0.835	0.821	0.807	0.793	0.779	0.765	0.751
340	0.906	0.892	0.878	0.864	0.850	0.835	0.821	0.807	0.793	0.779	0.765	0.751
350	0.906	0.892	0.878	0.864	0.850	0.836	0.822	0.808	0.794	0.780	0.766	0.752
360	0.906	0.892	0.878	0.864	0.850	0.836	0.822	0.808	0.794	0.780	0.766	0.752
370	0.907	0.893	0.878	0.864	0.850	0.836	0.822	0.808	0.794	0.780	0.766	0.752
380	0.907	0.893	0.879	0.865	0.851	0.837	0.823	0.809	0.795	0.781	0.766	0.752
390	0.907	0.893	0.879	0.865	0.851	0.837	0.823	0.809	0.795	0.781	0.767	0.753
400	0.908	0.894	0.880	0.866	0.851	0.837	0.823	0.809	0.795	0.781	0.767	0.753
410	0.909	0.895	0.880	0.866	0.852	0.838	0.824	0.810	0.795	0.781	0.767	0.753
420	0.910	0.895	0.881	0.867	0.853	0.839	0.824	0.810	0.796	0.782	0.767	0.753

6. Maintenance and Repair

At least once a season, remove the flow sensor to check for wear. High flow rates, debris and dirty water increase wear and require more frequent inspection.

WARNING!



Depressurize and vent system prior to performing the following procedure.

6.1 Sensor Removal

1. Turn off pump.
2. Turn off relief valve and drain the pipe.
3. Loosen and remove bolts, nuts and washers securing sensor to the installation fitting.

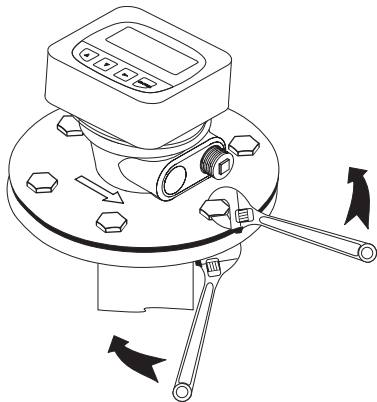

4. Lift and tilt the sensor slightly until you feel the rotor blade contact the inner pipe wall.
5. Gently lift and tilt sensor to align rotor blade for removal.

CAUTION: DO NOT FORCE! If resistance is felt while lifting sensor, repeat sequence until sensor can be removed without damaging it.

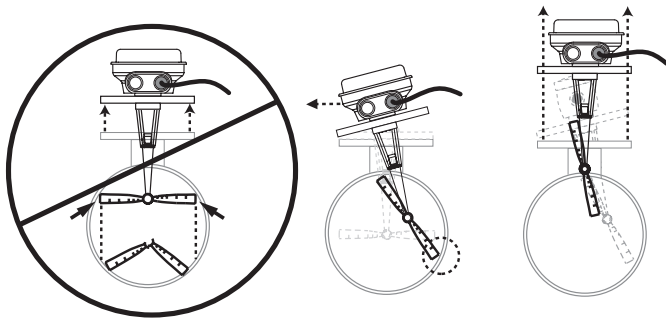

Note: If necessary, use a wire or stick to help reposition the rotor for removal.

6.2 Rotor Inspection

1. **Rotor Rotation:** Flick the rotor to check that it is "free spinning" and not bound or slow in rotating. If bearing binds, replace rotor assembly (P/N 4-3000.390).

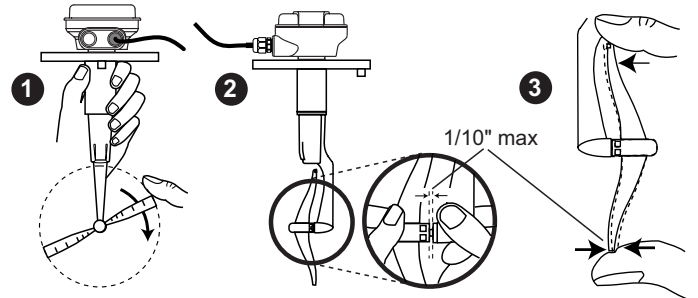

2. **Bearing Gap:** Grasp rotor and shaft and gently try to pull them apart. If there is a gap of more than 0.10-inch, replace rotor kit (P/N 4-3000.390).
3. **Wobble:** Wobble rotor blade from side-to-side. If blade wobbles more than 0.10-inch, replace rotor kit (P/N 4-3000.090).

6.3 Rotor Replacement

1. Insert a small screwdriver or coin under **rotor retaining clip** to release the rotor assembly from sensor body.

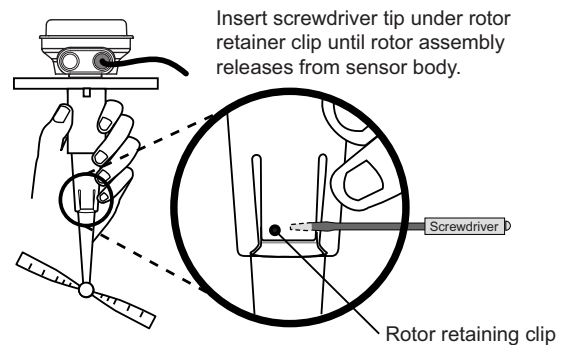

2. Gently separate halves. **DO NOT** overextend the rotor assembly retaining clip or it will break.

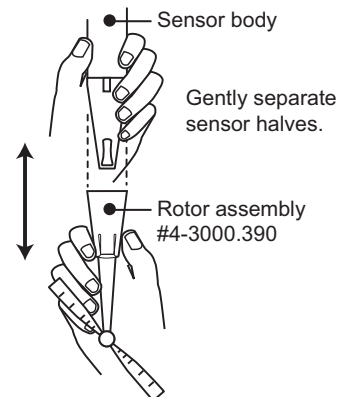

3. Reinstall sensor rotor assembly in reverse order. Assembly is keyed for proper orientation. When properly seated on the sensor body the retainer clip will "click" into position.

7. Custom Fitting Dimensions

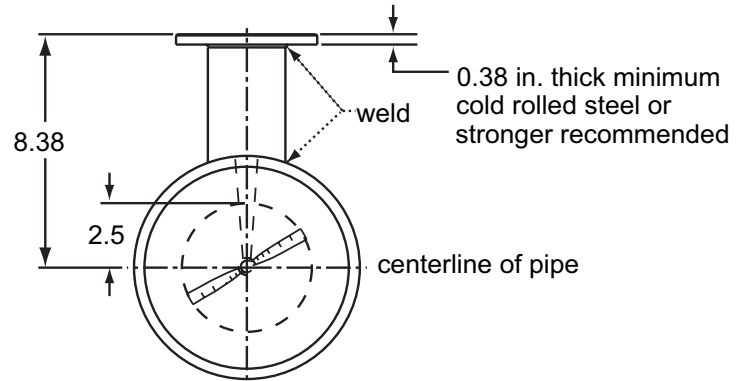
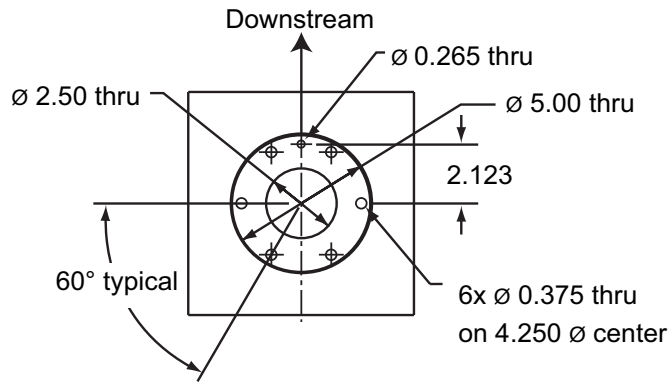

DIMENSIONS IN INCHES

8. Ordering Information

Mfr. Part No.	Description
4-3000-5	Irrigation Flow Sensor w/Integral Base
3-8150-1	Irrigation Flow Totalizer

Totalizer Parts and Accessories

Mfr. Part No.	Description
3-8050	Universal Mounting Kit
4-3110	Integral Base with Terminal Cover
4-3111	Terminal Cover
4-3112	Outer Cover Assembly
3-8054	Integral Base
3-9000.392-1	Liquid Tight Connector
5523-0222	Cable, Two-conductor Shielded, 22AWG, black, red, shield (per ft.)
7400-0011	Lithium Battery, 3.6V, Size AA

Sensor Parts and Accessories

Mfr. Part No.	Description
4-3000.566	Saddle, Irrigation, 6-inch O.D.
4-3000.568	Saddle, Irrigation, 8-inch O.D.
4-3000.570	Saddle, Irrigation, 10-inch O.D.
4-3000.572	Saddle, Irrigation, 12-inch O.D.
4-3000.566-W	Weldolet, Irrigation, 6 in.
4-3000.568-W	Weldolet, Irrigation, 8 in.
4-3000.570-W	Weldolet, Irrigation, 10 in.
4-3000.572-W	Weldolet, Irrigation, 12 in. and up
4-3000.390	Rotor kit, Irrigation sensor
4-3000.392	Cap-off kit, Irrigation saddle
4-3000.575	Irrigation saddle flange gasket

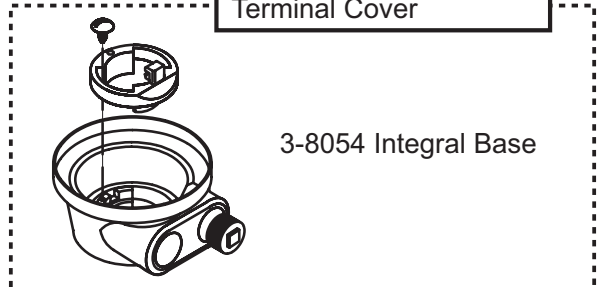
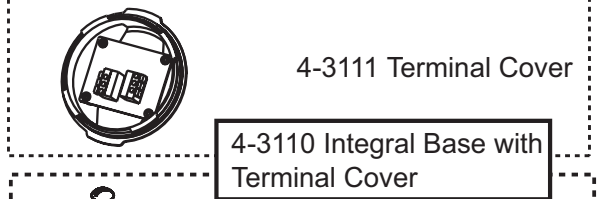
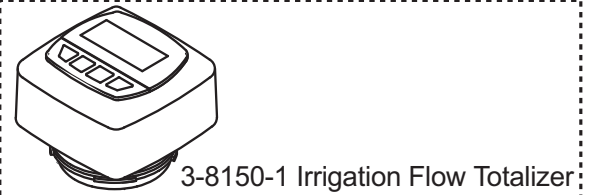
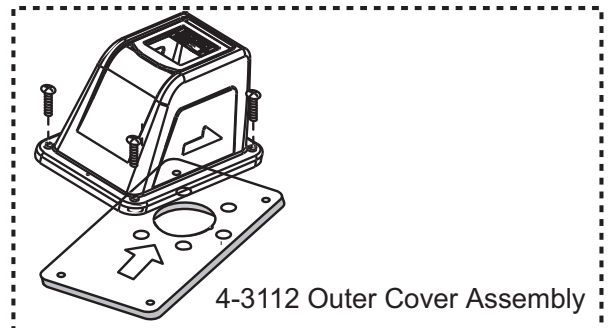
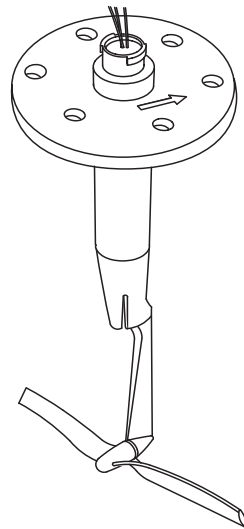

+GF+

George Fischer Signet, Inc. 3401 Aerojet Avenue, El Monte, CA 91731-2882 U.S.A. • Tel. (626) 571-2770 • Fax (626) 573-2057
For Worldwide Sales and Service, visit our website: www.gfsignet.com

