

USER'S GUIDE

Installation & Operation
Instructions

Doppler Flow Switch

Model DFS-II

Manual Series 1.5

INDEX

Introduction 3

Connections 4

Adjustments 4

Transducer Installation 5

Enclosure Installation 8

Principle of Operation 9

Applications Background 10

Typical DFS-II Control Applications 11

Troubleshooting 12

Applications Hotline 12

Product Return Procedure 13

Warranty 14

Specifications 15

Appendix A - Options 16

Appendix B - Flow Velocity Calculation 20

IMPORTANT NOTE: This instrument is manufactured and calibrated to meet product specifications. Please read this manual carefully before installation and operation. Any unauthorized repairs or modifications may result in a suspension of the warranty.

Available in Adobe Acrobat pdf format

INTRODUCTION

DOPPLER FLOW SWITCH - Model DFS-II

The Greyline Doppler flow switch consists of an encapsulated ceramic transducer, a transmitter/receiver unit, electronic circuitry to separate the Doppler frequency from the transmitted frequency and an adjustable set-point relay. The relay also has delay-on, delay-off and time delay capability.

The DFS-II Flow Switch is housed in a watertight NEMA4X fiberglass enclosure and requires a 115VAC power supply.

Flow measurement range is 0.25 to 10 ft/second (0.076 to 3 m/sec).



CONNECTIONS:

SENSOR: Connect one sensor coaxial cable to the RCVR and GND terminal block, and the second sensor coaxial cable to the TMTR and GND terminal block. TMTR and RCVR are the solid core of each coaxial cable, and GND is the stranded shield or green conductor of each coaxial cable.

POWER INPUT: Connect 115VAC 50/60Hz to the LINE, NEUTRAL and GROUND terminals. Do not apply power until sensor connections have been made.

QUICK BENCH TEST

To test operation of the DFS-II set Sensitivity to Maximum. Hold the sensor in one hand and briskly rub the face (plastic surface) with your thumb or fingers. Allow a few seconds for the DFS-II Signal Strength LED to illuminate.

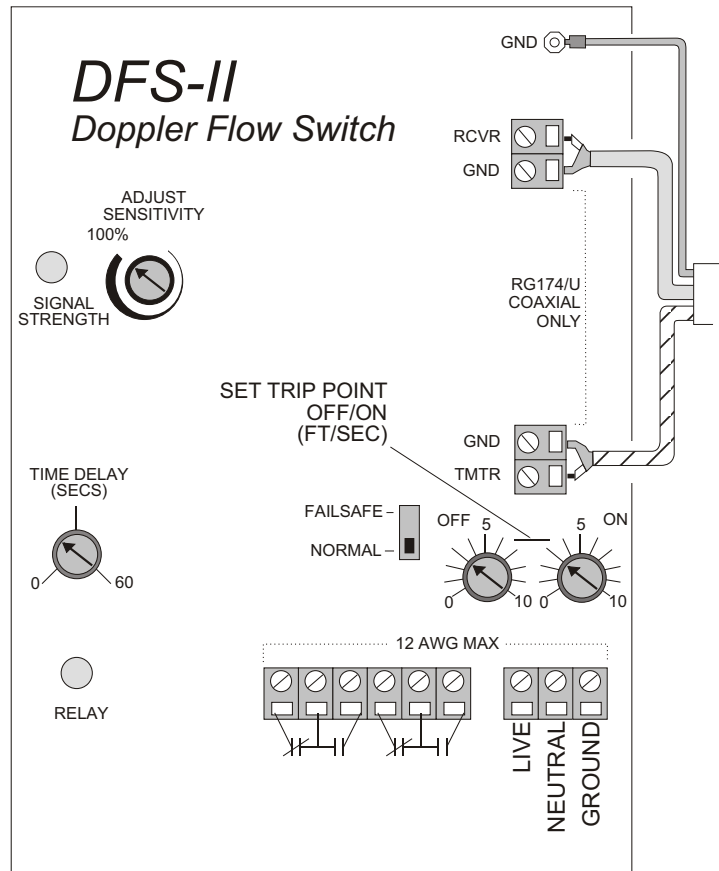

ADJUSTMENTS:

SENSITIVITY - The SIGNAL STRENGTH LED varies in intensity depending on signal strength. Under normal flow conditions adjust until the Signal Strength light is mid-intensity. Excessive Sensitivity adjustment (Maximum LED brightness) may result in nuisance alarms.

TIME DELAY - Adjust for up to 60 seconds delay after the switch senses an alarm condition.

NORMAL/FAILSAFE SWITCH –

NORMAL - Relay energizes when flow exceeds the ON set point.

FAILSAFE - Reverses operation of the relay. Relay de-energizes when flow exceeds the ON set-point. Allows the DFS-II to operate as a High flow alarm + Power loss alarm.

SET TRIP POINT - Two separate controls allow a relay deadband with ON/OFF set points from 0.25 to 10 ft/sec (0.076 to 3 m/sec)

Example: Set Relay “ON” at 5
 Set Relay “OFF” at 3
 Relay will switch ON when flow exceeds 5 ft/sec and OFF when it drops below 3 ft/sec.

TRANSDUCER INSTALLATION

MOUNTING LOCATION - The position of the sensor is one of the most important considerations for accurate Doppler flow measurement. The same location guidelines apply to Doppler as to most other types of flow switches.

VERTICAL OR HORIZONTAL PIPE - Vertical pipe runs generally provide evenly distributed flow conditions. On horizontal runs the sensor should be positioned at 3 or 9 o'clock to avoid concentrations of gas at the top of the pipe and solids on the bottom.

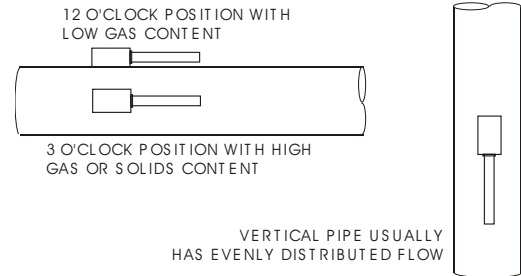

Generally the sensor must be mounted away from flow disturbances such as valves, pumps, orifice plates or venturis which tend to increase flow velocity or cause cavitation. Velocity increasing devices often cause cavitation and readings both up and downstream may show much higher velocity. As a guideline, mount the sensor 20 diameters upstream and 30 diameters downstream from velocity increasing devices.

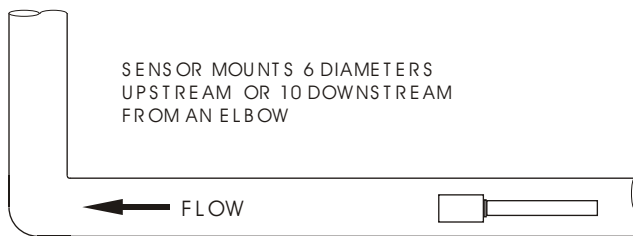

Turbulence Increasing Devices: Elbows, flanged connections and tees tend to introduce desirable conditions of an evenly distributed flow profile with some air or gases entrained in the flow. Sensor mounting *6 diameters upstream and 10 diameters downstream* from these disturbances is generally optimum.

The transducer is designed to mount longitudinally on a straight section of pipe. Do not attempt to mount it on bends, elbows or fittings. The DFS sensor measures flow in either direction.

Prepare an area 2 inches wide by 3 inches long for transducer bonding by removing all paint, scale and rust. Thoroughly degrease the surface to which the transducer will be bonded. The objective of site preparation is to eliminate any discontinuity between the transducer and the pipe wall which would prevent acoustical coupling.

For semi permanent or temporary bonding, the following are recommended:

- Dow Corning silicon compound #4. (Greyline Part #CC)
- Electrocardiograph gel.
- Petroleum gel.

The above are arranged in their order of preferred application. B & C are suggested only for room temperature application. **DO NOT USE: Silicon RTV compound (silicon rubber).**

One PCK Pipe Clamp Kit is included with each Greyline DFS-II. It includes recommended silicone coupling compound in a plastic applicator, a stainless steel sensor bracket, and a stainless strap for pipe diameters up to 16" 406 mm. Additional pipe clamps (optional) may be attached for larger diameter pipes.

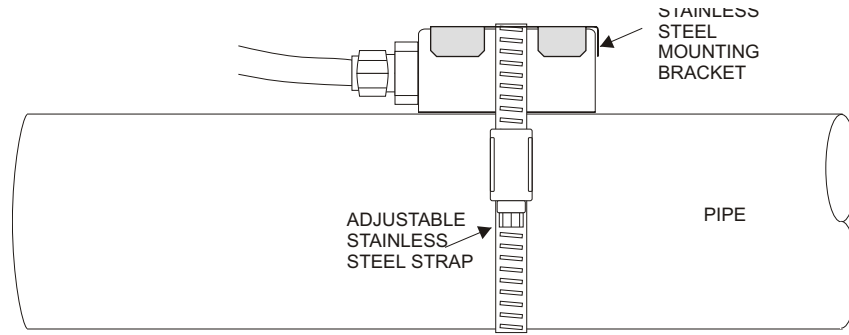

Thread the strap through the bracket and mount loosely on the pipe ready for Sensor coupling.

SENSOR COUPLING

Prepare a pipe clamp to secure the sensor. Apply coupling compound to the coloured face of the sensor. A bead (similar to toothpaste on a toothbrush) is ideal. Press the sensor on to the pipe and secure with the clamp. **DO NOT** overtighten.

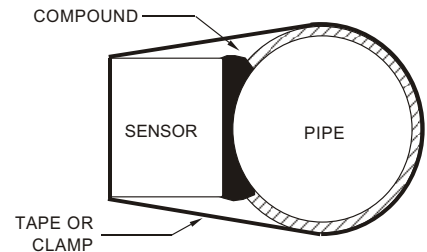
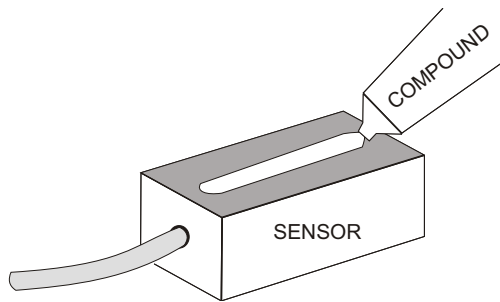

For proper operation the transducer must be fixed securely to the pipe with coupling material between the transducer face and the pipe. Sensor installation with excessive coupling compound or epoxy can result in gaps or voids in the coupling and cause errors or loss of signal. Insufficient coupling compound will create similar conditions.

Over time temporary coupling compounds may gradually sag away from the sensor resulting in reduced signal strength and finally complete loss of signal. Warm temperatures, water and vibration will accelerate this process. Loss of Signal will be indicated by the Signal Strength LED on the face of the DFS-II.

SENSOR COUPLING AND MOUNTING RECOMMENDATIONS

BAD

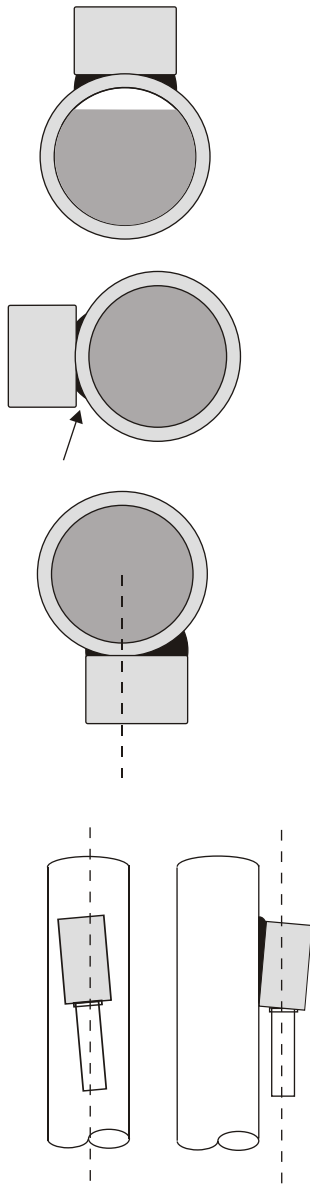

GOOD

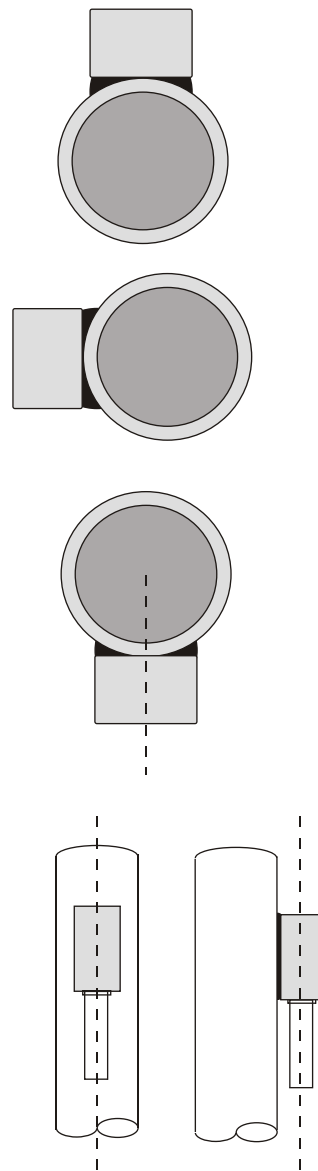

ENCLOSURE INSTALLATION

NEMA4X (IP66) WITH CLEAR COVER

LOCATION - Select a wall location within 20 ft (6 m) of the sensor mounting location. Sensor cable may be extended up to 500 ft (150 m) if enclosure installation is required at a remote location.

To protect the electronics from overheating and condensate build-up **DO NOT** mount the enclosure in direct sunlight. Avoid mounting on vibrating structures.

1. Remove enclosure cover.
2. Insert #8 screws and washers through the enclosure mounting holes to secure the enclosure to the wall or mounting stand.
3. Replace cover.

Additional conduit holes can be cut in the ends and side walls of the enclosure when required. Use a hole saw or Greenlee-type hole cutter.

Note: This non metallic enclosure does not automatically provide grounding between conduit connections. Grounding must be provided as part of the installation. Ground in accordance with the requirements of the National Electrical Code. System grounding is provided by connecting grounding wires from all conduit entries to the steel mounting plate or another point which provides continuity.

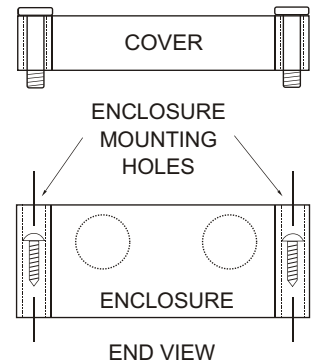

PRINCIPLE OF OPERATION

Greyline flow instruments continuously inject sound into the flowing liquid and measure the change in frequency of any echoes received from suspended particles, air bubbles, etc. in the liquid.

The sound frequency of 640,000 wave-lengths/second travels through the liquid at 4,800 feet/second (for water). The 640,000 wave-lengths occupy 4,800 feet. If the target is moving away from the receiver, the same number of wave-lengths has to occupy a bigger distance and so each wave-length appears longer. The longer wave-length means fewer wave-lengths/second or a lower frequency. The reverse is true if the target moves towards the receiver; the distance is shortened, the wave-length appears shorter and the frequency higher.

Greyline instruments measure only the change in frequency and will read the same whether the flow is towards or away from the transducer.

LAMINAR & TURBULENT FLOW - Two basic conditions exist in flowing liquids. One is turbulent flow, where the velocity of the fluid is the same at the pipe wall as it is in the center. The other is laminar flow, where the flow at the pipe wall is very slow and gradually increases to a maximum at the center of the pipe.

In the factory, all equipment is calibrated and tested against water with a 0.25% entrained air as the reflective medium. Pipe diameter does not affect accuracy and shown here are some typical results that may be expected in different situations.

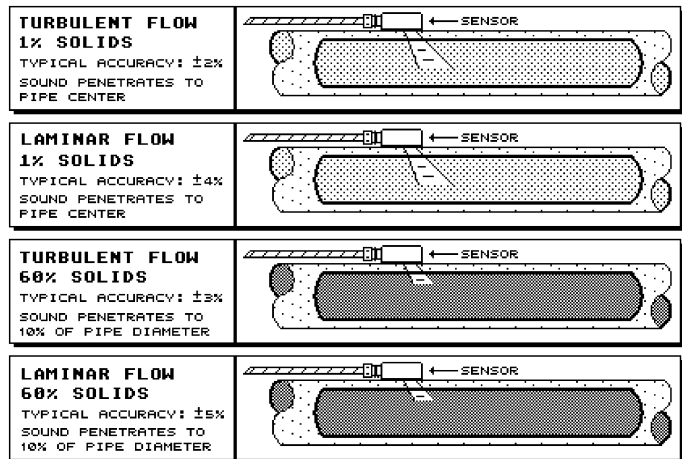

If the sound cannot penetrate to the center of the pipe, a laminar flow condition will cause the flow switch to read low due to a lower flow rate existing at the point at which sound reflections occur. This problem may be overcome by calibrating the switch on the pipe and comparing the readings with a known accurate flow meter, or by adjusting the set points while controlling flow at the desired set point velocities.

APPLICATIONS BACKGROUND

PIPE MATERIAL - Sound conductivity varies according to density of the pipe material. Porous materials such as concrete or pitted cast iron cause sound attenuation and Doppler performance may be erratic. Steel, aluminum, copper, PVC and other plastic pipes are generally ideal with minimal sound attenuation.

Avoid pipes with loose insertion liners where sound transmission may be broken by air gaps. Sound refraction may occur with some liner materials such as cement or coal tar as the Doppler signal travels through different densities of the liner and pipe wall. The resulting error can normally be corrected by calibration in situ.

PIPE DIAMETER - The standard SE3 sensor is designed to mount on pipes 1 inch (25mm) I.D. or larger. An optional small pipe sensor (Model SSE3) is available for pipe inside diameters of ½" or larger.

DEPOSITS - Scale or sediment deposits in older pipes alter the pipe cross-section resulting in high flow volume readings. Deposits can also cause sound attenuation and reduce Doppler signal strength.

NOISE INTERFERENCE - The Doppler circuit is designed to lock onto the strong Doppler return signal and to ignore most external process noise. Marginal applications, where the liquid contains minimal solids or gases require increased Sensitivity adjustment and may be more sensitive to external noise.

ELECTRICAL INTERFERENCE - High voltage sources or DC motors in very close proximity to the Doppler sensor, cable or electronics, can interfere with the Doppler signal. Stray mains voltage (50 or 60 Hz) can occasionally be measured on conductive pipes and care should be taken to eliminate the problem at its source.

POWER LINE FLUCTUATIONS - Voltage variances of $\pm 10\%$ of the instrument's nominal input will not affect performance or accuracy.

FLUID TEMPERATURE - Within the sensor tolerances (-40° to 200°F / -40° to 93°C) the Doppler accuracy will not be affected more than 0.3%. Higher or lower temperatures may damage or reduce the operating life of the sensor. Use optional high temperature sensor model SE3H for temperatures up to 302°F / 150°C .

CALIBRATION DRIFT - The DFS-II calibration does not drift over time. The solid state sensor has no moving parts to wear and affect calibration. The Doppler principle generates a digital signal proportional to the velocity of flow. All timing/counting circuits use crystal controlled references to eliminate any drift in the processing circuitry.

TYPICAL DFS-II CONTROL APPLICATIONS

1. HI FLOW ALARM (Eg: Alarm if flow exceeds 8 ft/sec.)

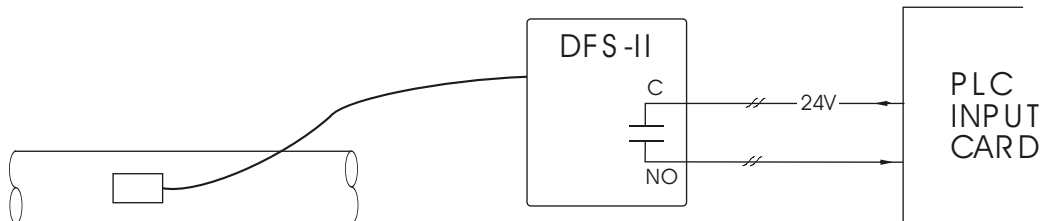

SETTINGS:

NORMAL
ON TRIP POINT = 8 FT/SEC
OFF TRIP POINT = 7.5 FT/SEC
DELAY = AS REQUIRED (TYPICAL ~ 10 SEC.)

2. HI FLOW ALARM WITH FAILSAFE: (Eg: Alarm if flow exceeds 5 ft/sec and if Power loss)

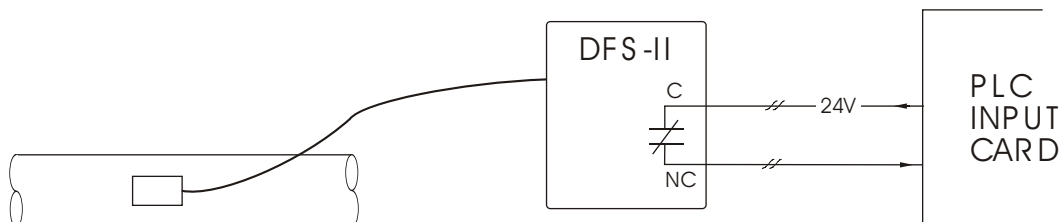

SETTINGS:

FAILSAFE
ON TRIP POINT = 5 FT/SEC
OFF TRIP POINT = 4 FT/SEC
DELAY = AS REQUIRED (TYPICAL ~ 10 SEC.)

3. PUMP PROTECTION CIRCUIT

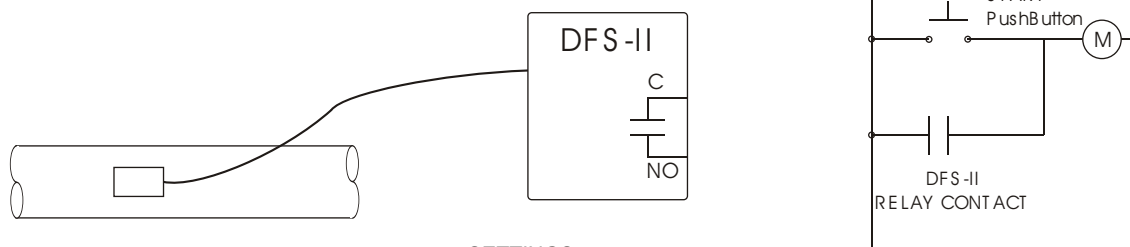

SETTINGS:

NORMAL
ON TRIP POINT = 0.5 FT/SEC
OFF TRIP POINT = 0 FT/SEC
DELAY = AS REQUIRED (TYPICAL ~ 20 SEC.)

TROUBLESHOOTING

<i>RELAY OPERATES WHEN THERE IS NO FLOW</i>	
Possible Cause:	<ul style="list-style-type: none"> - “ON” or “OFF” points set to less than 0 ft/sec - vibration on pipe - local electrical noise - Relay mode set to FAILSAFE
Corrective Action:	<ul style="list-style-type: none"> - adjust set points above 0 ft/sec - relocate sensor - reduce Sensitivity - set Relay mode to NORMAL
<i>ERRATIC OPERATION</i>	
Possible Cause:	<ul style="list-style-type: none"> - sensor mounted too close to pump, valve or elbow - sensor mounted without coupling compound
Corrective Action:	<ul style="list-style-type: none"> - change sensor placement - check coupling and coupling compound
<i>RELAY DOES NOT OPERATE</i>	
Possible Cause:	<ul style="list-style-type: none"> - “OFF” point higher than “ON” set point - relay “ON” point too high - power interruption
Corrective Action:	<ul style="list-style-type: none"> - adjust “ON” point higher than “OFF” set point - decrease relay “ON” set point - check fuse/breaker
<i>SIGNAL STRENGTH LED DOES NOT ILLUMINATE</i>	
Possible Cause:	<ul style="list-style-type: none"> - improper transducer connections - improper sensor mounting - not enough suspended particles or gases in fluid - no flow
Corrective Action:	<ul style="list-style-type: none"> - check transducer connections - check sensor mounting - relocate sensor or inject air into pipeline - confirm flow

APPLICATIONS HOTLINE

For applications assistance, advice or information on any Greyline Instrument contact your Sales Representative, write to Greyline or phone the Applications Hotline below:

United States: Tel: 315-788-9500 Fax: 315-764-0419
Canada: Tel: 613-938-8956 Fax: 613-938-4857
Toll Free: 888-473-9546
Email: info@greyline.com
Web Site: http://www.greyline.com

Greyline Instruments Inc.

Canada	USA:
16456 Sixsmith Drive	105 Water Street
Long Sault, Ont. K0C 1P0	Massena, NY 13662

PRODUCT RETURN PROCEDURE

Instruments may be returned to Greyline for service or warranty repair. Before shipping a product to the factory please contact Greyline by telephone or Fax to obtain an RMA number (Returned Merchandise Authorization). This ensures fast service and correct billing or credit.

When you contact Greyline please have the following information available:

1. Model number / Software Version
2. Serial number
3. Date of Purchase
4. Reason for return (description of fault or modification required)
5. Your name, company name, address and phone number

After obtaining an RMA number please ship the product to the appropriate address below:

*Canadian and International
Customers:*

Greyline Instruments Inc.
16456 Sixsmith Drive
Long Sault, Ont. K0C 1P0

RMA#

*USA
Customers:*

Greyline Instruments Inc.
105 Water Street
Massena, NY 13662

RMA#

LIMITED WARRANTY

Greyline Instruments warrants, to the original purchaser, its products to be free from defects in material and workmanship for a period of one year from date of invoice. Greyline will replace or repair, free of charge, any Greyline product if it has been proven to be defective within the warranty period. This warranty does not cover any expenses incurred in the removal and re-installation of the product.

If a product manufactured by Greyline should prove defective within the first year, return it freight prepaid to Greyline Instruments along with a copy of your invoice.

This warranty does not cover damages due to improper installation or handling, acts of nature, or unauthorized service. Modifications to or tampering with any part shall void this warranty. This warranty does not cover any equipment used in connection with the product or consequential damages due to a defect in the product.

All implied warranties are limited to the duration of this warranty. This is the complete warranty by Greyline and no other warranty is valid against Greyline. Some states do not allow limitations on how long an implied warranty lasts or limitation of incidental or consequential damages, so the above limitations or exclusions may not apply to you.

This warranty gives you specific legal rights, and you may also have other rights which vary from state to state.

Greyline Instruments Inc.

SPECIFICATIONS

- Sensor Mounting:** Silicone coupling compound, PCK stainless steel Pipe Clamp Kit for 0.5" / 12.5 mm OD pipes or larger
- Electronics Enclosure:** watertight, dust-tight NEMA4X (IP67) polycarbonate
- Output:** 1 Relay – 5 ampere DPDT
- Set Point:** On/Off adjustment 0.25 – 10 ft/sec (0.076 – 3 m/sec)
- Relay Time Delay:** adjustable, 0-60 seconds
- Failsafe Mode:** switch selectable
- Indication:** Relay and Signal strength LED's
- Sensitivity:** adjustable
- Power Input:** 100–130VAC 50-60Hz, (4.2 W max.)
Optional: 200-260VAC 50-60Hz, (4.8 W max.)
Optional: 24VDC, (3.6 W max.)
- Surge Protection:** sensor, AC power input

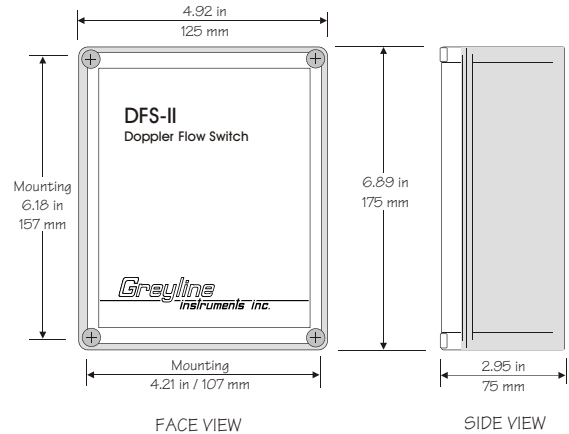

STANDARD SENSOR SE3

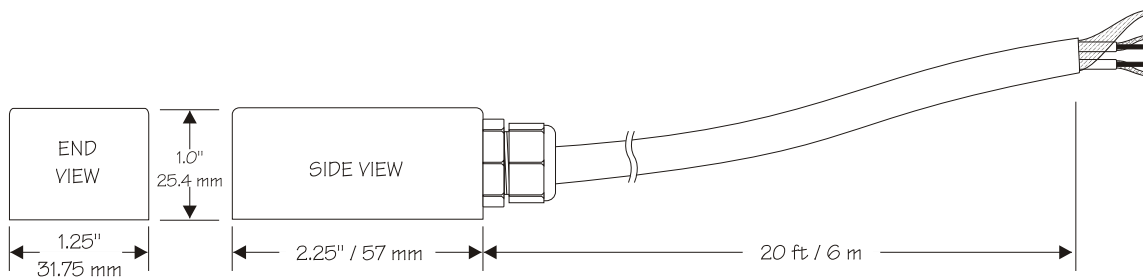

- Minimum Pipe Diameter:** 0.5" (12.5 mm) ID, 0.6" (15 mm) OD
- Maximum Pipe Diameter:** 180" (4.5 m) ID
- Operating Temperature:** -40° to 200°F (-40° to 93°C)
- Operating Frequency:** 640KHz
- Sensor Housing:** Stainless Steel with Epoxy face
- Sensor Cable:** 20 ft. (6 m) shielded coaxial pair (RG174U)
Optional 50 ft (15 m) continuous
- Submersion Rating:** Withstands accidental submersion pressure up to 10 psi (0.7 Bar)
- Hazardous Locations:** Rated for sensor and cable installation in Class I, Div. I,II, Groups C,D,E,F,G Hazardous locations with optional Intrinsic Safety Barriers

APPENDIX A - OPTIONS

EXTRA SENSOR CABLE

(OPTION DXC)

Each Greyline flow switch includes 20 ft. (6m) shielded coaxial pair cable. Additional cable and Cable Junction Box (Option DJB) may be ordered with the Flow Switch, or the cable may be spliced and extended up to 500 ft (152m) as required during installation. No adjustment is required when the sensor cable is extended or shortened.

Use only Greyline shielded coaxial pair cable. Extended sensor cable can be installed in conduit for mechanical protection. Recommended installation with a metal junction box is illustrated below:

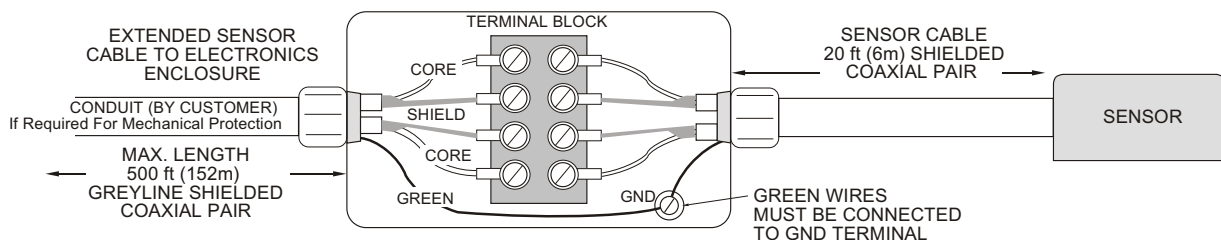

Note: Instead of Greyline Option DXC shielded coaxial pair, you may substitute RG174U coaxial cable from your local electrical cable distributor but this cable is not shielded so extended cable must be installed in metal conduit.

COAXIAL CABLE PREPARATION

DXC Doppler sensor cable can be cut and spliced up to a maximum length of 500 ft (152 m). Cable ends must be prepared as illustrated below.



SENSOR CABLE JUNCTION BOX (OPTION DJB)

Optional Watertight steel NEMA4 Junction Boxes with terminal strips are available from Greyline Instruments.

DIMENSIONS OPTION DJB - JUNCTION BOX

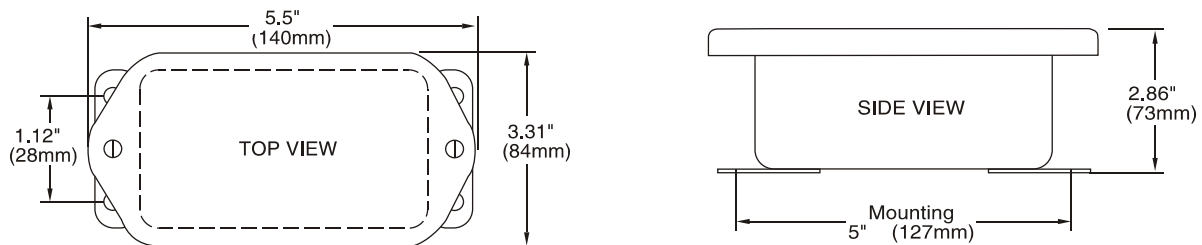

230VAC 50-60Hz POWER INPUT (OPTION EI)

DFS-II-EI Flow Switches with optional 230VAC power input are shipped factory configured for 230VAC power input. Connections are made to Line, Neutral and Ground as illustrated in the Manual section titled CONNECTIONS.

24VDC POWER INPUT (OPTION DC)

DFS-II-DC Flow Switches are factory configured for 24VDC power input.

SE3H – HIGH TEMPERATURE DOPPLER SENSOR

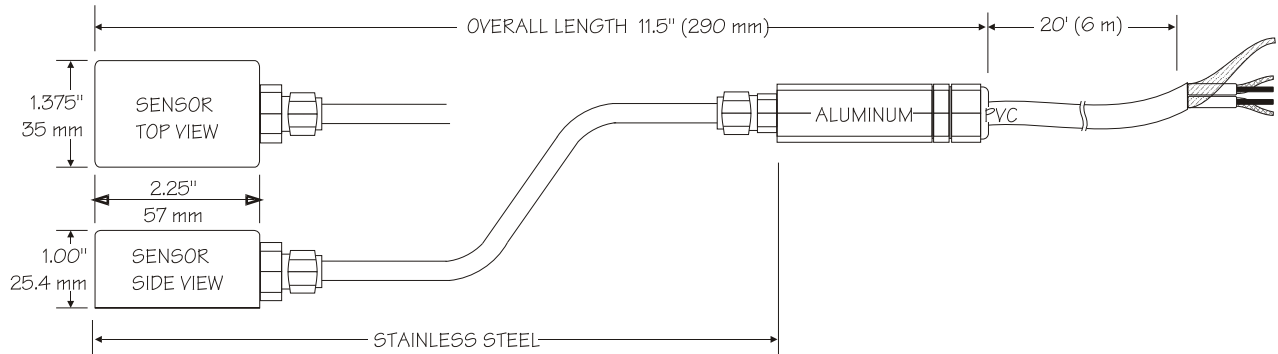

Minimum Pipe Diameter: 0.5" (12.5 mm) ID, 0.6" (15 mm) OD

Maximum Pipe diameter: 180" (4.5 m) ID

Operating Temperature: -40 to 302 F (-40 to 150 C)

Operating Frequency: 640KHz

Sensor Housing: Stainless Steel with Epoxy face

Sensor Cable: 20 ft. (6 m) RG174U shielded coaxial pair

Note: Protect sensor cable from contact with hot pipes.

ISE - INSERTION FLOW SENSOR

Insertion Depth: 1/8th pipe inside diameter plus 3/4" (20 mm).

Orientation: Screw head makes the active face and should point upstream ±5 .

Average Flow Rate: Before permanent tightening of swage lock fitting, the probe can be inserted to variable depths to determine the flow profile. Theoretical average flow occurs at 1/8 pipe diameter.

Installation Procedure: Install a 1" NPT Female Nipple on the pipe. Insert probe. Tighten swage lock until it just grips the Probe – then tighten 3/4 of a turn. Do not use above 100 psi.

Maximum Pressure: 100 psi (6.75 bar)
Maximum Temperature: 200 F (93 C)
Minimum Temperature: -10 F (-23 C)
Maximum Pipe Diameter: 48" (1.2 m) ID
Minimum Pipe Diameter: 2" (50 mm) ID
Insertion Length: 1/8 dia.+ 3/4" (19 mm)
Sensor Cable: 20 ft. (6 m) RG174U shielded coaxial pair

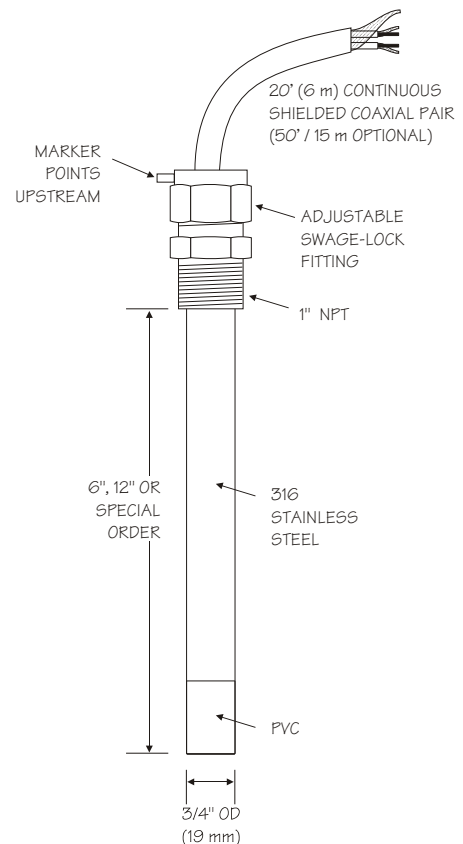

SENSOR INTRINSIC SAFETY

(Option 2ISB)

When connected through Intrinsic Safety Barriers, the Greyline Sensor Model SE3 is CSA certified for installation in a hazardous location rated:

- Class I, Groups C, D
- Class II, Groups E, F and G
- Class III

Intrinsic Safety Barriers may be ordered with the Greyline instrument and are supplied mounted in the Greyline instrument enclosure. Replacement barrier fuses (Part No. ISB- 011239) may be purchased separately. The Instrument Enclosure containing the 2ISB Intrinsic Safety Barriers must be installed in a non-hazardous location. The Sensor, connecting cable and Junction boxes may be located in the hazardous rated area.

Intrinsic Safety Barrier Specifications: Certified, rated 9.3V max, 25 ohms min.

(Recommended: Stahl Model 9001/02-093-390-10).

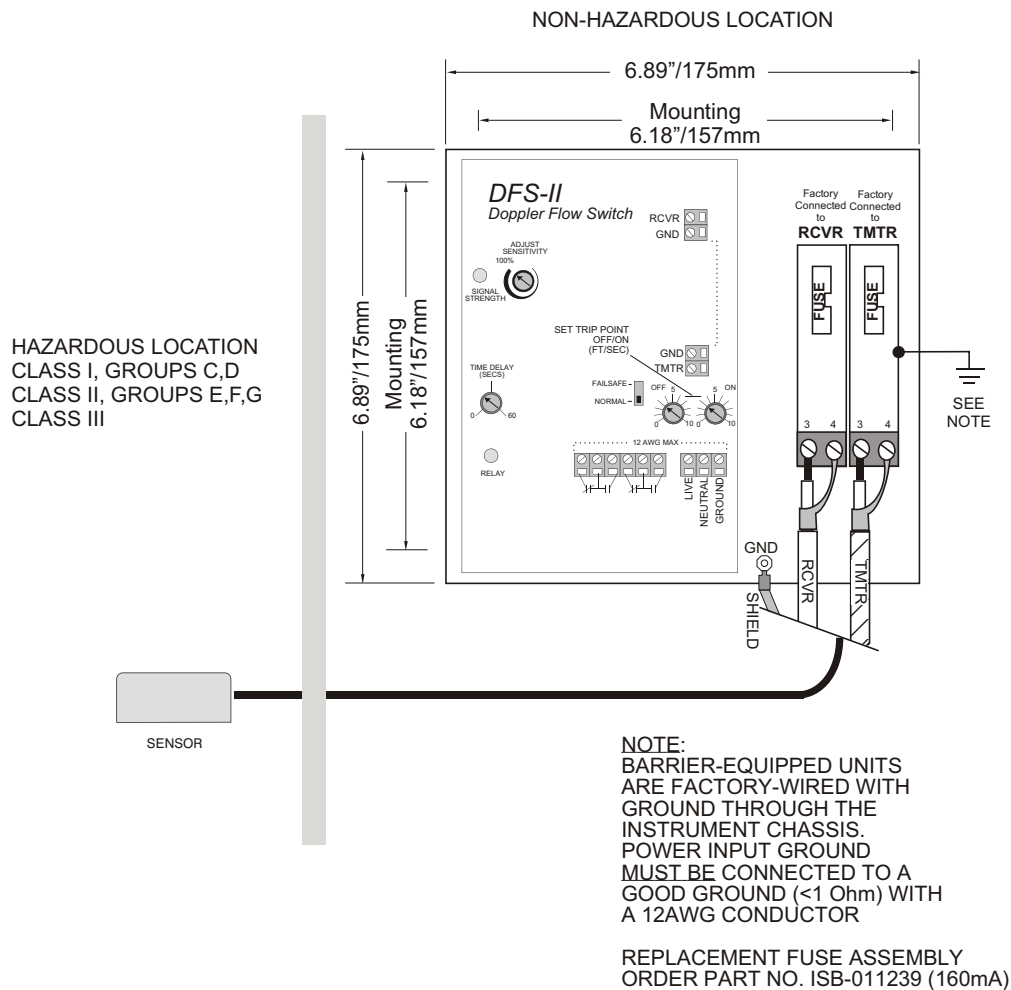

APPENDIX B

FLOW VELOCITY CALCULATION

Flow velocity can be calculated from the following data.

<u>KNOWN FLOW</u>	<u>DIVIDED BY</u>	<u>VELOCITY</u>
U.S. gallons/sec.	0.0408 x (pipe I.D.) ²	= ft/sec
U.S. gallons/min.	2.448 x (pipe I.D.) ²	= ft/sec
Imp. gallons/sec	0.0340 x (pipe I.D.) ²	= ft/sec
Imp. gallons/min	2.040 x (pipe I.D.) ²	= ft/sec
Litres/sec	0.1545 x (pipe I.D.) ²	= ft/sec
Litres/min	9.270 x (pipe I.D.) ²	= ft/sec
Cubic metres/sec	0.0001545 x (pipe I.D.) ²	= ft/sec
Cubic metres/min	0.00927 x (pipe I.D.) ²	= ft/sec

EXAMPLE: 3" ID pipe

$$\text{Known Flow of 160 US gallons/min: } \frac{160}{2.448 \times (3)^2} = 7.26 \text{ ft/sec}$$

FLOW CHART U.S. Gallons per Minute

Pipe	Velocity in Feet per Second									
ID in.	1.0	2.0	3.0	4.0	5.0	6.0	7.0	8.0	9.0	10.0
0.5	0.6	1.2	1.8	2.4	3.1	3.7	4.3	4.9	5.5	6.1
0.8	1.4	2.8	4.1	5.5	6.9	8.3	9.6	11.0	12.4	13.8
1.0	2.4	4.9	7.3	9.8	12.2	14.7	17.1	19.6	22.0	24.5
1.3	3.8	7.7	11.5	15.3	19.1	23.0	26.8	30.6	34.4	38.3
1.5	5.5	11.0	16.5	22.0	27.5	33.1	38.6	44.1	49.6	55.1
2.0	9.8	19.6	29.4	39.2	49.0	58.8	68.5	78.3	88.1	97.9
2.5	15.3	30.6	45.9	61.2	76.5	91.8	107.1	122.4	137.7	153.0
3.0	22.0	44.1	66.1	88.1	110.2	132.2	154.2	176.3	198.3	220.3
3.5	30.0	60.0	90.0	120.0	149.9	179.9	209.9	239.9	269.9	299.9
4.0	39.2	78.3	117.5	156.7	195.9	235.0	274.2	313.4	352.5	391.7
5.0	61.2	122.4	183.6	244.8	306.0	367.2	428.4	489.6	550.8	612.0
6.0	88.1	176.3	264.4	352.5	440.7	528.8	616.9	705.1	793.2	881.3
8.0	156.7	313.4	470.0	626.7	783.4	940.1	1096.8	1253.5	1410.1	1566.8
10.0	244.8	489.6	734.4	979.3	1224.1	1468.9	1713.7	1958.5	2203.3	2448.2
12.0	352.5	705.1	1057.6	1410.1	1762.7	2115.2	2467.7	2820.3	3172.8	3525.3
14.0	479.8	959.7	1439.5	1919.3	2399.2	2879.0	3358.9	3838.7	4318.5	4798.4
16.0	626.7	1253.5	1880.2	2506.9	3133.6	3760.4	4387.1	5013.8	5640.5	6267.3
18.0	793.2	1586.4	2379.6	3172.8	3966.0	4759.2	5552.4	6345.6	7138.8	7932.0
20.0	979.3	1958.5	2937.8	3917.0	4896.3	5875.6	6854.8	7834.1	8813.3	9792.6
24.0	1410.1	2820.3	4230.4	5640.5	7050.7	8460.8	9870.9	11281.1	12691.2	14101.3
30.0	2203.3	4406.7	6610.0	8813.3	11016.7	13220.0	15423.3	17626.7	19830.0	22033.4
36.0	3172.8	6345.6	9518.4	12691.2	15864.0	19036.8	22209.6	25382.4	28555.2	31728.0
42.0	4318.5	8637.1	12955.6	17274.1	21592.7	25911.2	30229.8	34548.3	38866.8	43185.4
48.0	5640.5	11281.1	16921.6	22562.2	28202.7	33843.2	39483.8	45124.3	50764.8	56405.4
Pipe	Velocity in Feet per Second									
ID in.	11.0	12.0	13.0	14.0	15.0	16.0	17.0	18.0	19.0	20.0
0.5	6.7	7.3	8.0	8.6	9.2	9.8	10.4	11.0	11.6	12.2
0.8	15.1	16.5	17.9	19.3	20.7	22.0	23.4	24.8	26.2	27.5
1.0	26.9	29.4	31.8	34.3	36.7	39.2	41.6	44.1	46.5	49.0
1.3	42.1	45.9	49.7	53.6	57.4	61.2	65.0	68.9	72.7	76.5
1.5	60.6	66.1	71.6	77.1	82.6	88.1	93.6	99.2	104.7	110.2
2.0	107.7	117.5	127.3	137.1	146.9	156.7	166.5	176.3	186.1	195.9
2.5	168.3	183.6	198.9	214.2	229.5	244.8	260.1	275.4	290.7	306.0
3.0	242.4	264.4	286.4	308.5	330.5	352.5	374.6	396.6	418.6	440.7
3.5	329.9	359.9	389.9	419.9	449.8	479.8	509.8	539.8	569.8	599.8
4.0	430.9	470.0	509.2	548.4	587.6	626.7	665.9	705.1	744.2	783.4
5.0	673.2	734.4	795.6	856.9	918.1	979.3	1040.5	1101.7	1162.9	1224.1
6.0	969.5	1057.6	1145.7	1233.9	1322.0	1410.1	1498.3	1586.4	1674.5	1762.7
8.0	1723.5	1880.2	2036.9	2193.5	2350.2	2506.9	2663.6	2820.3	2977.0	3133.6
10.0	2693.0	2937.8	3182.6	3427.4	3672.2	3917.0	4161.9	4406.7	4651.5	4896.3
12.0	3877.9	4230.4	4582.9	4935.5	5288.0	5640.5	5993.1	6345.6	6698.1	7050.7
14.0	5278.2	5758.0	6237.9	6717.7	7197.6	7677.4	8157.2	8637.1	9116.9	9596.7
16.0	6894.0	7520.7	8147.4	8774.2	9400.9	10027.6	10654.3	11281.1	11907.8	12534.5
18.0	8725.2	9518.4	10311.6	11104.8	11898.0	12691.2	13484.4	14277.6	15070.8	15864.0
20.0	10771.9	11751.1	12730.4	13709.6	14688.9	15668.2	16647.4	17626.7	18605.9	19585.2
24.0	15511.5	16921.6	18331.7	19741.9	21152.0	22562.2	23972.3	25382.4	26792.6	28202.7
30.0	24236.7	26440.0	28643.4	30846.7	33050.0	35253.4	37456.7	39660.0	41863.4	44066.7
36.0	34900.8	38073.6	41246.4	44419.2	47592.0	50764.8	53937.6	57110.4	60283.2	63456.0
42.0	47503.9	51822.4	56141.0	60459.5	64778.0	69096.6	73415.1	77733.7	82052.2	86370.7
48.0	62045.9	67686.5	73327.0	78967.5	84608.1	90248.6	95889.1	101529.7	107170.2	112810.8