



# EasyTREK

SP-300, SP-300 series  
two-wire compact ultrasonic  
level transmitter

## INSTALLATION AND PROGRAMMING MANUAL

2<sup>nd</sup> edition



---

Manufacturer:  
**NIVELCO Process Control Co.**  
H-1043 Budapest, Dugonics u. 11.  
Tel.: (36-1)-889-0100 ♦ Fax: (36-1)-889-0200  
e-mail:sales@nivelco.com ♦ <http://nivelco.com>

---

# BASIC CONCEPTS AND ELEMENTS OF ULTRASONIC MEASUREMENT

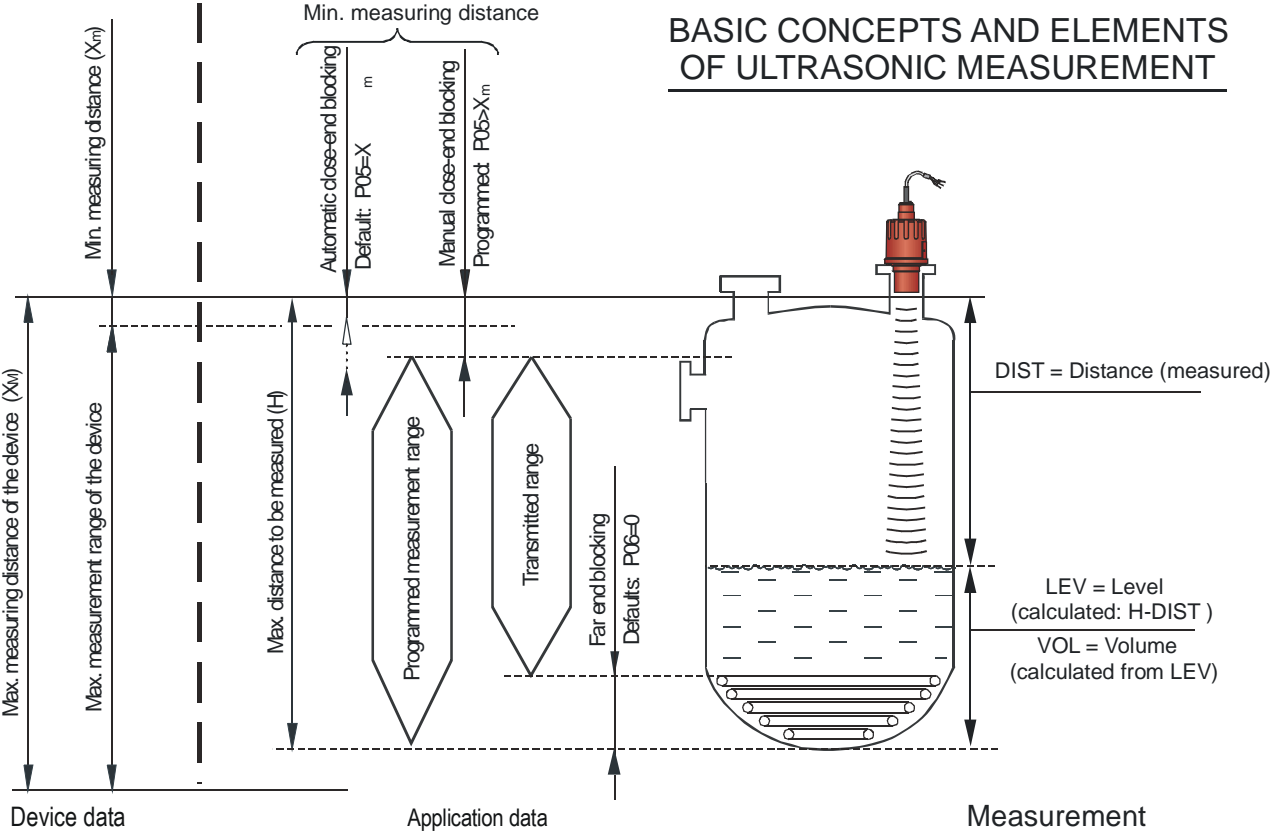

# CONTENTS

1. INTRODUCTION.....	5	5.3.2. Current output .....	20
2. TECHNICAL DATA .....	6	5.3.3. Digital communication .....	21
2.1 General data.....	6	5.3.4. Measurement optimisation .....	21
2.2 Additional data for Ex certified devices .....	5	5.3.5. Volume (content) measurement.....	25
2.3 Special data.....	7	5.3.6. Open channel flow measurement .....	26
2.4 Accessories .....	7	5.3.7. 32-Point linearisation.....	32
2.5 Order codes (Not all combinations are available) .....	7	5.3.8. Informational parameters (read out parameters) .....	33
2.6 Dimensions.....	8	5.3.9. Additional parameters for flow metering.....	34
3. INSTALLATION.....	9	5.3.10. Other parameters .....	34
3.1 Liquid level measurement .....	9	6. MAINTENANCE AND REPAIR .....	34
3.2 Open channel flow measurement .....	11	7. ERROR CODES .....	35
4. WIRING .....	11	8. PARAMETER TABLE .....	36
5. PUTTING INTO OPERATION .....	12	9. SOUND VELOCITY VALUES IN DIFFERENT GASES .....	38
5.1. Usage .....	12		
5.2. Safety regulations for units with Ex approvals .....	13		
5.3. Programming.....	14		
5.3.1. Measurement configuration.....	14		



*Thank you for choosing a NIVELCO instrument.  
We are sure that you will be satisfied throughout its use.*

## 1. INTRODUCTION

### Application

The EasyTREK compact ultrasonic level transmitters from NIVELCO are excellent tools for level measurement of liquids.

Level measurement technology based on the non-contacting ultrasonic principle is especially suited for applications where, for any reason, no physical contact can be established to the surface of the material to be measured.

### Principle of Operation

The ultrasonic level metering technology is based on the principle of measuring the time required for the ultrasound pulses to make a round trip from the sensor to the level to be measured and back. The sensor emits an ultrasonic pulse train and receives the echoes reflected. The intelligent electronic device processes the received signal by selecting the echo reflected by the surface and calculates from the time of flight the distance between the sensor and the surface which constitutes the basis of all output signals of the EasyTREK.

Minimum measuring distance ( $X_m$ ) is determined by the design of the unit within which the measurement is not possible (Dead Zone) its value is according with P05 on page 26. Since measurement is impossible within this range material should not get into this zone.

Maximum measuring distance ( $X_M$ ) is the greatest distance (determined by the design of the unit) which can be measured by the unit under ideal conditions. (See parameter P04 on page 25). Maximum measuring distance of the actual application (H) must not be greater than  $X_M$ .

A Total beam angle of  $5^\circ$ - $7^\circ$  at  $-3$  dB as is featured by most of Nivelco's SenSonic transducers ensuring a reliable measurement in narrow silos with uneven side walls as well as in process tanks with various protruding objects. Furthermore, as a result of the narrow beam angle - the emitted ultrasonic signals have an outstanding focusing - deep penetration through gases, vapour and foam is ensured.

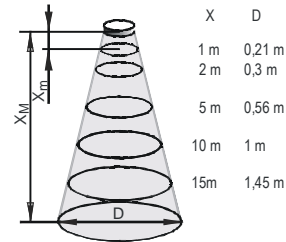

Diameters  
corresponding to  
 $5^\circ$  beam angle.

## 2. TECHNICAL DATA

### 2.1 GENERAL DATA

Transducer/enclosure materials	Polypropylene (PP), PVDF, PTFE/PP	
Process temperature	PP, PVDF and PTFE transducers -30°C...+90°	
Ambient temperature	-30 °C ... +80 °C	
Pressure** (Absolute)	0,05 ... 0,3 MPa (0,5 ... 3 bar) SS316Ti for sensors with stainless steel 0,09 ... 0,11 MPa (0,9 ... 1,1 bar)	
Seals	PP transducer: EPDM ; All other transducer versions: FPM	
Ingress protection	IP 68	
Power supply	11,8 ... 36 V DC without HART communication	48 mW ... 720 mW, Galvanic isolation; protection against surge transients
	1,2 ... 36 V DC with HART communication	
Accuracy *	± (0.2% of the measured distance plus 0.05% of the range)	
Resolution	Depending on the measured distance: < 2 m: 1 mm, 2 ... 5 m: 2 mm, 5 ... 10 m: 5 mm, > 10 m: 10 mm	
Outputs	Analogue: 4 ... 20 mA, (3,9 ... 20,5 mA), $R_{tmax} = (U_t - 11,4 V) / 0,02 A$ , Galvanic isolation; protection against surge transients	
	Serial communication: HART interface (terminal resistor 250 Ohm)	
Electrical connection	2 x 0,5 mm <sup>2</sup> shielded cable Ø6mm x 3m (available max. length 30m)	
Electrical protection	Class III SELV	

\* Under optimal circumstances of reflection and stabilised transducer temperature.

\*\* For pressures below 1 bar representative of Nivelco should be consulted.

### 2.2 ADDITIONAL DATA FOR EX CERTIFIED DEVICES

Ex marking	 II1G EEx ia IIB T6 IP68
Intrinsically safety data	$C_i \leq 15 \text{ nF}$ , $L_i \leq 200 \text{ } \mu\text{H}$ , $U_i \leq 30 \text{ V}$ , $I_i \leq 140 \text{ mA}$ , $P_i \leq 1 \text{ W}$ Ex-device should be powered by EEx ia power supply
Ex power supply, loading	$U_o < 30 \text{ V}$ , $I_o < 140 \text{ mA}$ , $P_o < 1 \text{ W}$ , Voltage range 12 V ... 30 V, $R_{tmax} = (U_t - 12 \text{ V}) / 0,02 \text{ A}$
Medium temperature	For PP transducer -20 °C ... +70 °C, for PVDF transducer -20 °C ... +80 °C, for PTFE transducer -30 °C ... +90 °C
Ambient temperature	-20 °C ... +70 °C

## 2.3 SPECIAL DATA

SPECIAL DATA FOR PP, PVDF AND PTFE TRANSDUCERS (ALSO APPLIES TO EX MODELS)

Type	SP□-39□-□		SP□-38□-□		SP□-37□-□		SP□-36□-□	SP□-34□-□
Transducer material	PP, PVDF	PTFE	PP, PVDF	PTFE	PP, PVDF	PTFE	PP or PVDF	PP or PVDF
Max measuring distance * (X <sub>M</sub> ) [m / ft]	4/13	3/10	6/20	5/16	8/26	6/20	10/33	15/49
Min. measuring distance* (Dead band) [m / ft]	0.2/0,65	0.25//0,82	0.25//0,82	0.25//0,82	0.35/1,2	0.35/1,2	0.35/1,2	0.45/1,5
Total beam angle (-3dB)	6°		5°		7°		5°	5°
Measurement frequency	80 kHz		80 kHz		50 kHz		60 kHz	40 kHz
Process connection	1" BSP and 1 1/2" BSP/NPT		1" BSP and 2" BSP/NPT		1" BSP and 2" BSP/NPT		1" BSP	1" BSP

\* (from the transducer face)

## 2.4 ACCESSORIES

- Warranty certificate
- Installation and programming manual
- Certificate of conformity

## 2.5 ORDER CODES (NOT ALL COMBINATIONS ARE AVAILABLE)

EasyTREK S P □ - 3 □ □ - □

HOUSING MATERIAL	CODE
PP	A
PVDF	B
PTFE / PP	T

RANGE * M/FEET	CODE
15/49	4
10/33	6
6/20 ; 8/26	7
5/16 ; 6/20 m	8
3/10 ; 4/13	9

PROCESS CONNECTION	CODE
1"; 2" BSP thread	0
2" NPT thread	N
1" BSP quick conn. / PP	F
Bracket 200 mm	K
Bracket 500 mm	L
Bracket 700 mm	M

OUTPUT / Ex	CODE
4 ... 20 mA / HART / LOGGER	3
4 ... 20 mA / HART	4
4 ... 20 mA / HART / LOGGER / Ex	7
4 ... 20 mA / HART / Ex	8

Certified devices bear the „Ex“ tag in the order code

\* Measuring range depends on the material of the transducer

## 2.6 DIMENSIONS

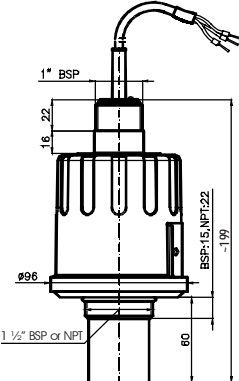
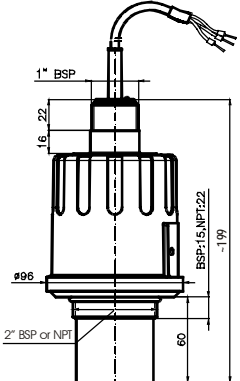
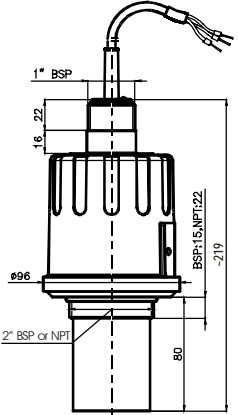
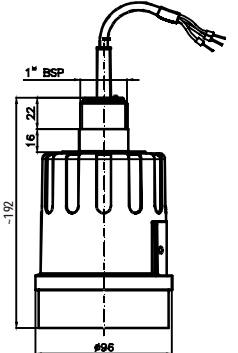
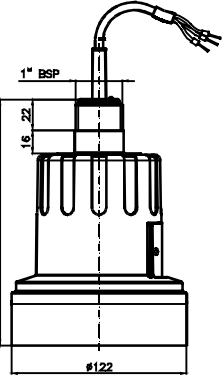
EasyTREK SP□-39□-□ / PP, PVDF, PTFE	EasyTREK SP□-38□-□ / PP, PVDF, PTFE	EasyTREK SP□-37□-□ / PP, PVDF, PTFE	EasyTREK SP□-36□-□ / PP, PVDF, PTFE	EasyTREK SP□-34□-□ / PP, PVDF, PTFE
 <p>1" BSP</p> <p>16.22</p> <p>1.99</p> <p>#96</p> <p>80</p> <p>1 1/2" BSP or NPT</p> <p>BSP:15,NPT:22</p>	 <p>1" BSP</p> <p>16.22</p> <p>1.99</p> <p>#96</p> <p>60</p> <p>2" BSP or NPT</p> <p>BSP:15,NPT:22</p>	 <p>1" BSP</p> <p>16.22</p> <p>2.19</p> <p>#96</p> <p>80</p> <p>2" BSP or NPT</p> <p>BSP:15,NPT:22</p>	 <p>1" BSP</p> <p>16.22</p> <p>1.92</p> <p>#96</p>	 <p>1" BSP</p> <p>16.22</p> <p>1.73</p> <p>#122</p>

## 3. INSTALLATION

### 3.1 LIQUID LEVEL MEASUREMENT

#### POSITION

The ideal position of the EasyTREK is on the radius  
 $r = (0.3 \dots 0.5) R$  of the (cylindrical) tank / silo.  
(Take also sonic cone on page 1 into consideration.)

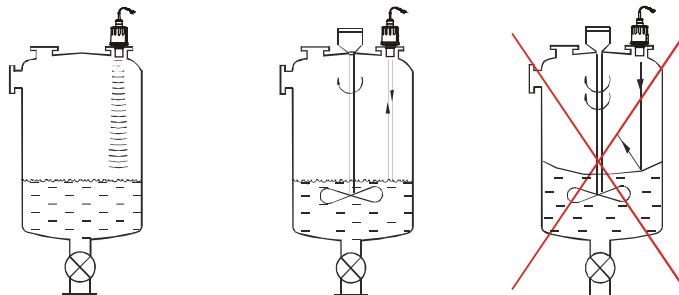

#### SENSOR ALIGNMENT

The sensor face has to be parallel to the surface of the liquid within  $\pm 2-3^\circ$ .

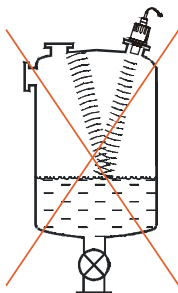

#### TEMPERATURE

Make sure that the transmitter is protected against overheating by direct sunshine.

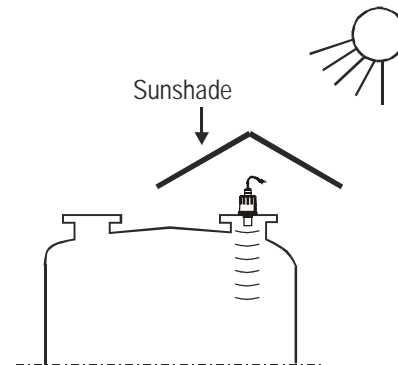

## OBSTACLES

Make sure that no objects (cooling pipes, bracing members, thermometers etc.) protrude into the sensing cone of the ultrasonic beam.

**Remark:** EasyTREK programming allows one fixed object that would otherwise disturb the measurement to be blocked out. (see **P29** of programming).

## FOAM

Foaming of the liquid surface may render ultrasonic level metering impossible. If possible, a location should be found, where foaming is the least (device should be located as far as possible from liquid inflow) or a stilling pipe or well should be used.

## STAND-OFF

The structure of the stand off pipe should be rigid; the inner rim where the ultrasonic beam leaves the pipe should be rounded.

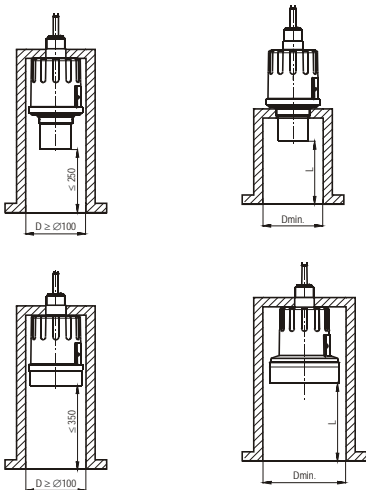

## WIND

Intensive air (gas) movements in the vicinity of the ultrasonic cone is to be avoided. A strong draft of wind may "blow away" the ultrasound. Devices with lower measuring frequency (40, 20 kHz) are recommended.

## FUMES / VAPOURS

For closed tanks containing chemicals or other liquids, which creates fume/gases above the liquid surface especially for outdoor tanks exposed to the sun, a strong reduction of the nominal measuring range of the ultrasonic device is to be considered during device selection. Devices with lower measuring frequency (40, 20 kHz) are recommended in these cases.

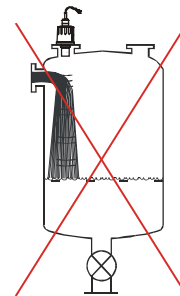

L	D <sub>min</sub>		
	SP □ - 39 □	SP □ - 38 □	SP □ - 37 □
150	50	60	60
200	50	60	75
250	65	65	90
300	80	75	105

L	D <sub>min</sub>
	SP □ - 34 □
90	*
200	*
350	*
500	*

\* For values contact your distributor

## 3.2 OPEN CHANNEL FLOW MEASUREMENT

- The unit is suitable for open channel flow measurement with the constructive works listed in 5.3.6.
- For ultimate accuracy, install the sensor as close as possible above the expected maximum water level (see minimum measuring range).
- Install the unit in a place defined by the characteristics of the metering channel along the longitudinal axis of the flume or weir. In case of Parshall flumes supplied by NIVELCO the location of the sensor is marked.
- In some cases foam may develop on the surface. Make sure that the surface, opposite to the sensor, remains free of foam for proper sound reflection.
- The unit should be fixed so that its position would not change.
- From measurement accuracy point of view the length of the channel sections preceding and following the measuring flume and their method of joining to the measuring channel section are of critical importance.
- Despite of the most careful installation, the accuracy of flow metering will be lower than that of specified for the distance measurement. The features of the flume or weir applied will determine it.
- Devices should be protected against overheating due to direct sunshine by using sunshades.

## 4. WIRING

- Make sure the terminals in the box are not under power (Use shielded cable 2 x 0,5 mm<sup>2</sup> suggested in the technical data or stronger).
- After powering the necessary programming can be performed.

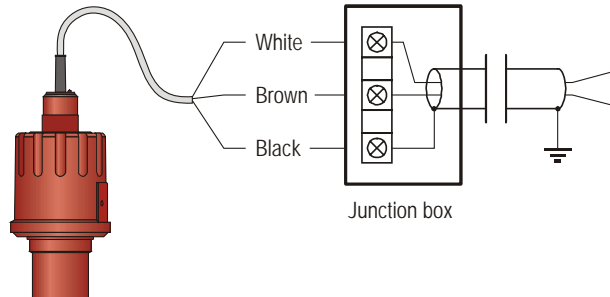

### Wire colours:

- White - I+ positive point of the power supply and HART
- Brown - I- negative point of the power supply and HART
- Black - GND Shielding to be grounded at the controller

### Extension of the integrated cable:

Should extension be needed the use of connection box is suggested.  
The shielding of the two cables should be connected and grounded at the signal processing device.

## 5. PUTTING INTO OPERATION

### 5.1. USAGE

Subsequent to powering the correctly wired device would start to tick and after 10 - 20 s ECHO LED go on and 4 ... 20 mA signal appears on the current output. Measurement will be according to the factory setting. The factory setting is throughout apt to check proper working and to perform simple measurement tasks but features residing in the unit can only be utilised by adjusting the EasyTREK to the application by programming. For sound knowledge of the operation features and proper solving of difficult measurement applications the parts of the programming should carefully be studied.

LED indication:

- ECHO-LED  
ON, if the unit detects proper echo
- COM-LED  
Blinking on HART communication  
Is ON in the state of remote programming

*View of the transmitter neck from above:*

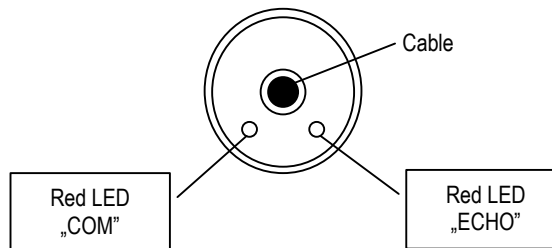

Device can be reset to factory setting. Default of EasyTREK SP-300 is the following:

- ⇒ Measurement: level (LEV)
- ⇒ Zero level assigned to the maximum distance
- ⇒ Current output proportional to the level
- ⇒ 4 mA and 0% assigned to zero level.
- ⇒ 20 mA and 100% assigned to the maximum level (minimum distance)
- ⇒ Error indication by the current output: holds last value.
- ⇒ Damping: 60 s.

## 5.2. SAFETY REGULATION FOR THE Ex APPROVED UNITS

Diameter of the cable should match the cable conduit.

The cable outside the unit should be fixed so that it should be free of loading.

The terminal box should be selected in accordance with the electrical class of the area.

Transmitter can only be powered by certified intrinsically safe current loop.

The enclosure of the transducer is plastic that can be loaded electrostatically therefore:

- Filling and emptying speed should be selected according to the medium
- Fog development of the dangerous material during filling should be avoided.
- Cleaning of the plastic enclosure is not allowed in hazardous space.

The apparatus is not suitable for flame-barrier between the space and the outside area.

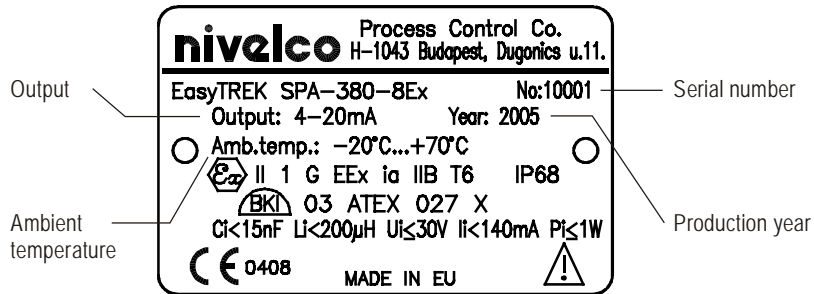

### 5.3. PROGRAMMING

The HART interface of the EasyTREK provides for access to the whole parameter set and possibility of their programming. Parameter set can be reached in two different ways: by the use of the

- EView software run on the PC connected through HART modem to the loop or
- Nivelco made MultiCONT multi-channel process control unit.

Since these access methods differ in their form and handling present manual does not review them. The information is contained in the relevant descriptions and user's manuals.

#### 5.3.1. MEASUREMENT CONFIGURATION

P00: - c b a Engineering Units

FACTORY DEFAULT: 000

*Programming of this parameter will result in loading the factory default with the corresponding engineering units.  
Therefore all parameters should be set again!*

a	Operation
0	Liquid level measurement

b	Engineering units (according to "c")	
	Metric	US
0	m	ft
1	cm	inch

c	Calculation system
0	metric
1	US

Parameter value „a” will determine the basic measurement value that will be transmitted. Subsequently values for the relays are also relating to these quantities.

a	Measurement mode	Transmitted value	Display symbol
0	Distance	Distance	DIST
1	Level	Level	LEV
2	Level %		LEV%
3	Volume	Volume	VOL
4	Volume %		VOL%
5	Flow	Flow	FLOW

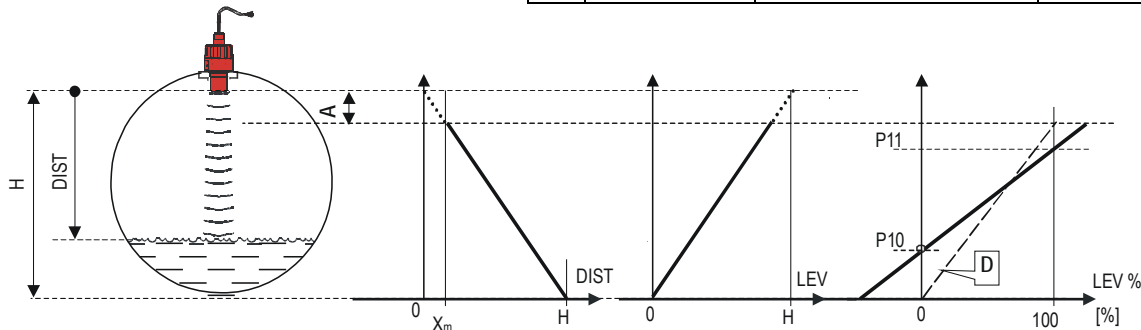

Transmitted value	DIST	LEV=H-DIST	$LEV\% = LEV \cdot \frac{P11 - P10}{H - X_m} + P10$
Parameters to set	P00 P01(a) = 0 P05 ≥ Xm	P00 P01(a) = 1 P04 = H P05 ≥ Xm	P00 P01(a) = 2 P04 = H P05 ≥ Xm P10 = X0% P11 = X100%

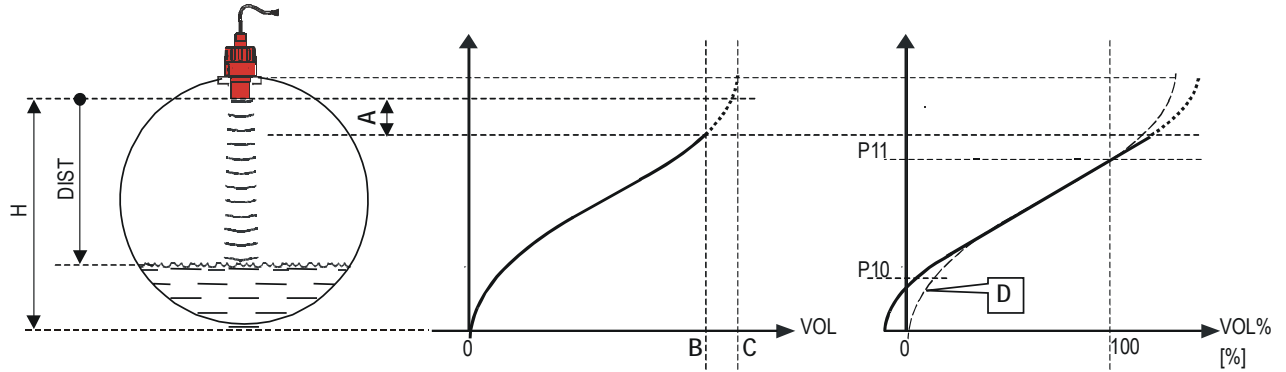

Transmitted value	VOL $f_{P40...P45}(H-DIST)$	$VOL\% = VOL * \frac{P_{11} - P_{10}}{H - X_m} + P_{10}$
Parameters to set	P00 P01(a) = 3 P02(b) P04 = H P05 $\geq X_m$ P40...P45	P00 P01(a) = 4 P02(b) P04 = H P05 $\geq X_m$ P10 = $X_{0\%}$ P11 = $X_{100\%}$ P40...P45

- A: Shortest measurable distance
- B: Volume (content) pertaining to the greatest measurable level
- C: Whole value of the vessel
- D: diagram valid for the default value of P10 P11

a	Temperature
	°C
1	°F

This table is interpreted according to P00(c), P01(a) and P02(c) and is irrelevant in case of percentage measurement [ P01(a)= 2 or 4 ]

b	Volume		Weight (set also P32)		Volume flow	
	Metric	US	Metric	US	Metric	US
	m <sup>3</sup>	ft <sup>3</sup>	-	lb (pound)	m <sup>3</sup> /time	ft <sup>3</sup> /time
1	litre	gallon	tons	tonnes	litre/time	gallon/time

c	Time
	s
1	min
2	hour
3	day

#### Attention!

EasyTREK is a level transmitter. Although it can be used for measuring weight, due to factors involved in doing so, accuracy may essentially be influenced.

This is the only parameter that has to be programmed for each application other than distance (however to avoid disturbing effect of possible multiple echoes it is suggested to do this in distance measurement applications too).

The maximum distance to be measured is the greatest distance between the surface of the transducer and the farthest level to be measured. The factory programmed, greatest distances (DEFAULT values) which can be measured by the units are listed in the table below. For the actual application the maximum distance to be measured i.e. the distance between the sensor and the bottom of the tank should be entered in P04.

EasyTREK Level transmitter for liquids	Maximum measuring distance X <sub>M</sub> [m/feet]	
	Transducer material PP / PVDF	Transducer material PTFE
SP_-39	4/13	3/10
SP_-38	6/20	5/16
SP_-37	8/26	6/20
SP_-36	10/33	-
SP_-34	15/49	-

Since the level is determined by calculating the difference between the value set in P04 and distance (DIST) is measured by the unit, it is essential that the correct value of (H) is set in P04. To obtain the best accuracy it is suggested that this distance is measured in the empty tank.

The range, beginning with the sensor's surface, within which (due to the physical restraint of the ultrasound measurement system) measurement can not be made, is called the dead zone. The EasyTREK will not accept any echo within the blocking distance set here.

Close end blocking may be represented as the extension of the dead zone within which a possible echo will not be taken into consideration making possible to exclude disturbing objects near to the sensor.

**Automatic Close-end-blocking = Dead Band control (P05 =  $X_m$ )**

Device with factory default will automatically *set the smallest possible dead band* depending on the conditions of the operation. This will be under optimal conditions a bit smaller in unfavourable circumstances greater than value given in the chart.

**Automatic Close-end-blocking with limitation  $\geq$  dead zone (P05 >  $X_m$ )**

By entering a value, higher than the factory default the close-end blocking will be either the value programmed in P05 or the actual dead zone distance (influenced by the actual conditions of the application) whichever is greater.

EasyTREK for liquids	Minimum measuring distance $X_m$ [m/feet]	
	Sensor material PP / PVDF	Sensor material PTFE
S-39	0,2/0,65	0,2/0,65
S-38	0,25/0,82	0,25/0,82
S-37	0,35/1,2	0,35/1,2
S-36	0,35/1,2	-
S-34	0,45/1,5aggregation	-

Far end blocking is the range below the level set in parameter P06. The far-end blocking can be used to avoid disturbing effect of stirrer or heaters at the bottom of the tanks. Detecting echoes in this range the unit provides special signals.

### **A.) Measuring level or content**

*Level sinking below*

- the value of P06 current output is according to the value of the far-end blocking and further
- below SUB 0 (7/8 of P06) the ERROR CODE 10 will be transmitted via HART

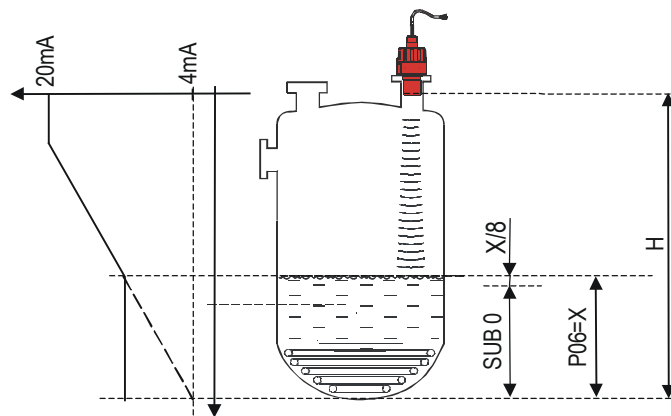

- *Level rising over value of far-end blocking:*

The calculation of level and volume will be based on the programmed tank dimensions, therefore the measured or calculated process values will not be influenced in any way, by the far end blocking value.

### **B.) Open channel flow metering**

Far end blocking will be used for those small levels below which the accurate volume flow calculation is no longer possible.

- *Level in the flume/weir sinking below the blocked out range:*
  - Output current value will be according to the value of  $Q = 0$
  - 0 value transmitted via HART for display of „No Flow” or 0
- *Level in the flume/weir rising over the blocked out range:*

The calculation of volume flow will be based on the programmed flume/weir data; therefore the measurement values will not be influenced in any way, by the far end blocking value.

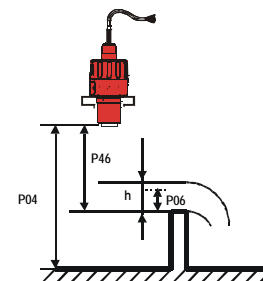

## 5.3.2. CURRENT OUTPUT

P08: - - - - Fixed current output

FACTORY DEFAULT: 0

By this step the output current can be set for a fix value selected from between 3,8 mA and 20,5 mA. This function is not operational as per the factory default: 0. **Attention: fixing output current will make settings in P10, P11, P12 and P19 irrelevant.**

P10: - - - - Value (of distance, level, volume or flow) assigned to 4 mA current output

FACTORY DEFAULT: 0

P11: - - - - Value (of distance, level, volume or flow) assigned to 20 mA current output

FACTORY DEFAULT:  $X_M - X_m$

A Values are interpreted according to P01(a). Assignment can be made so that the proportion between the change of the (measured or calculated) process value and the change of the current output be either direct or inverse. E.g. level 1 m assigned to 4mA and level 10 m assigned to 20 mA represents direct proportion and level 1 m assigned to 20 mA and level 10 m assigned to 4 mA represents the inverse proportion. Please note that in case of programming for (LEV or VOL) % measurement the min and max value has to be entered in the relevant engineering units of LEV (m, ft) or VOL ( $m^3$ ,  $ft^3$ ).

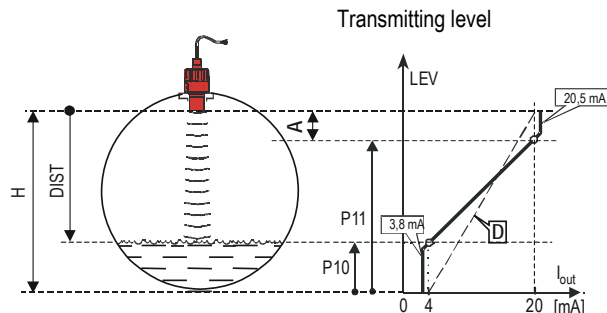

A: Smallest measurable dist.  
D: diagram valid for default values of P10 and P11

P12: - - - a Error indication by the current output

FACTORY DEFAULT: 0

In case of error the EasyTREK will provide one of the current outputs below for the time the error prevails. (For errors see Chapter 7).

a	Error indication by output current
0	HOLD (hold last value)
1	3,6 mA
2	22 mA

### 5.3.3. DIGITAL COMMUNICATION

P19: --- a Short (HART) address of the unit FACTORY DEFAULT: 2

These addresses with 0 ... 15 are, in accordance with the HART standard, for distinguishing units in the same loop.

- Address: 0 current output of 4 ... 20 ma operational
- Address: 1 ... 15 current output is fixed to 4 mA.

### 5.3.4. MEASUREMENT OPTIMISATION

P20: --- a Damping FACTORY DEFAULT: 5

This parameter can be used to reduce unwanted fluctuation of the display and output.

a	Damping (s)	No or moderate fume / waves	Heavy or dense fume or turbulent waves
0	no filter	For testing only	
1	3	applicable	not recommended
2	6	recommended	applicable
3	10	recommended	recommended
4	30	recommended	recommended
5	60	recommended	recommended

P22: --- a Dome top tank compensation FACTORY DEFAULT: 0

This parameter can be used to reduce disturbing effect of possible multiple echoes

a	Compensation	Remark
0	OFF	In case the EasyTREK is not mounted in the centre of the top and the top is flat.
1	ON	In case the EasyTREK is mounted in the centre of a tank with dome-shaped top

P24: --- a Target tracking speed FACTORY DEFAULT: 0

In this parameter evaluation can be speed up at the expense of the accuracy.

a	Tracking speed	Remark
0	Standard	For most applications
1	Fast	For fast changing level
2	Special	Only for special applications (measuring range is reduced to 50% of the nominal value) The measuring window is inactive and the EasyTREK will respond practically instantly to any target.

A so-called measuring window is formed around the echo signal. The position of this measuring window determines the flight time for calculation of the distance to the target. (the picture below can be seen on the test oscilloscope)

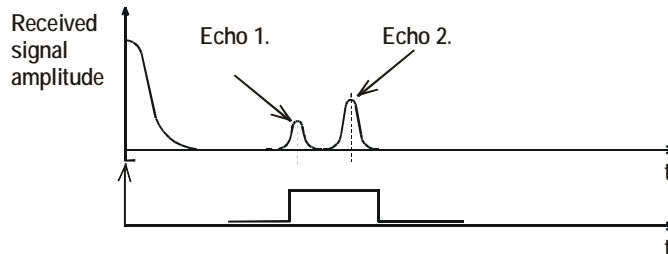

Some applications involve multiple (target + disturbing) echoes even within the measuring window. Basic echo selection will be done by the Quest + software automatically. This parameter influences the echo selection only within the measuring window.

a	Echo in the window to be selected	Remark
0	With the highest amplitude	Most frequently used
1	First one	For liquids applications with multiple echoes within the Measuring Window

P26: - - - - Level elevation rate (filling speed) (m/h or ft/h) FACTORY DEFAULT: 2000

P27: - - - - Level descent rate (emptying speed) (m/h or ft/h) FACTORY DEFAULT: 2000

These parameters provide additional protection against echo loss in applications involving very heavy fuming. Correct setting increases reliability of the measurement during filling and emptying. The parameters must not be smaller than the fastest possible filling/emptying rate of the actual technology.

**Attention!** Level changing rate is rather different near to the conical or spherical bottom of such a vessel.

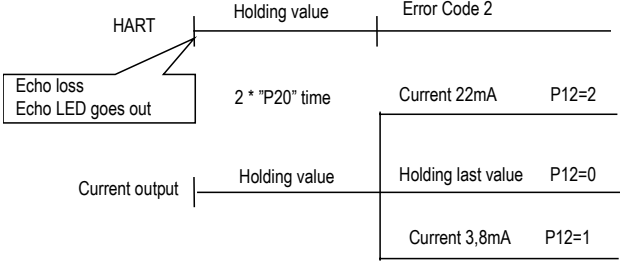
a	Echo loss indication	Remark
0	Delayed indication	<p>During short echo-loss (for the period of twice the time set in P20) analogue output will hold last value. After this period the current value according to the setting in P12 and via HART ERROR CODE 2 will be transmitted.</p> 
1	No indication	For the time of echo-loss, analogue output will hold last value.
2	Filling simulation	Loosing echo during the filling process, transmitted value will increase according to the filling speed set in P26
3	Immediate indication	Loosing echo the current value (according to the setting in P12) and the ERROR CODE 2 (via HART) will immediately be transmitted.
4	Empty tank indication	Echo-loss may occur in completely empty tanks with a spherical bottom due to deflection of the ultrasonic beam, or in case of silos with an open outlet. In such cases it may be useful to indicate empty tank instead of echo loss.

**P29 - - - - Blocking out of disturbing object** **FACTORY DEFAULT: 0**

One fixed object in the tank, disturbing the measurement, can be blocked out. By the use the Echo Map (P70) the precise distance of disturbing object can be read out. This value should be entered in this parameter.

**P31: - - - - Sound velocity at 20°C (m/s or ft/s depending on P00(c))** **FACTORY DEFAULT:: 343,8 (m/s), 1128 (ft/s)**

This parameter should be used if the sound velocity in the gases above the measured surface differs largely from that of in the air. This is recommended for applications where the gas is more or less homogeneous. If it is not, the accuracy of the measurement can be improved using 32-point linearisation (P48, P49).

*For sound velocities in various gases see section "Sound Velocities".*

**P32: - - - - Specific gravity** **FACTORY DEFAULT: 0**

Entering a value (other than "0") of specific gravity in this parameter, the weight will be displayed instead of VOL.

Engineering unit should be [kg/dm<sup>3</sup>] or [lb/ft<sup>3</sup>] depending on P00 (c)

### 5.3.5. VOLUME (CONTENT) MEASUREMENT

P40: --ba Tank shape

FACTORY DEFAULT: 00

ba	Tank shape	Also to be set
b0	Standing cylindrical tank shape (value of "b" as below)	P40 (b), P41
01	Standing cylindrical tank with conical bottom	P41, P43, P44
02	Standing rectangular tank (with chute)	P41, P42, P43, P44, P45
b3	Lying cylindrical tank shape (value of "b" as below)	P40 (b), P41, P42
04	Spherical tank	P41

**Attention!**  
The value „a“ determining the shape of the tank should be set first.

P41-45: - - - Tank dimensions

FACTORY DEFAULT: 0

Standing cylindrical tank with hemispherical bottom a=0

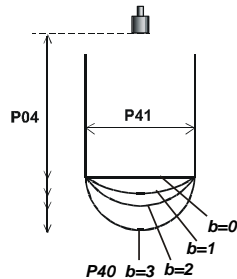

Standing cylindrical tank with conical bottom a=1 b=0

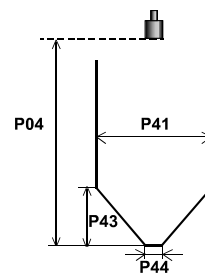

Standing rectangular tank with or without chute a=2 b=1

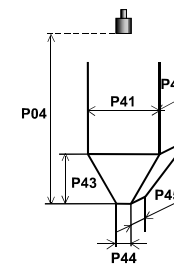

Plain bottom  
P43, P44 and  
P45 = 0

Lying cylindrical tank a = 3

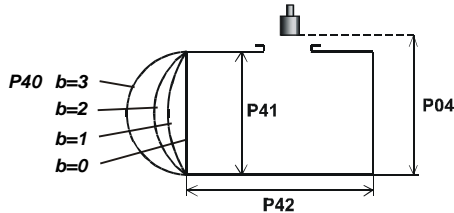

Spherical tank a = 4, b = 0

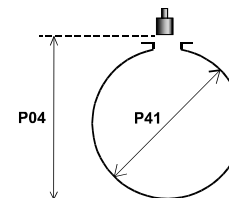

### 5.3.6. OPEN CHANNEL FLOW MEASUREMENT

P40: -- b a Devices, formula, data

FACTORY DEFAULT: 00

ba	Devices, formula, data					Also to be set	
	Type	Formula	Qmin [l/s]	Qmax [l/s]	"P" [cm]		
00	Nivelco Parshall channels	GPA-1P1	$Q [l/s] = 60.87 \cdot h^{1.552}$	0.26	5.38	30	P46
01		GPA-1P2	$Q [l/s] = 119.7 \cdot h^{1.553}$	0.52	13.3	34	P46
02		GPA-1P3	$Q [l/s] = 178.4 \cdot h^{1.555}$	0.78	49	39	P46
03		GPA-1P4	$Q [l/s] = 353.9 \cdot h^{1.558}$	1.52	164	53	P46
04		GPA-1P5	$Q [l/s] = 521.4 \cdot h^{1.558}$	2.25	360	75	P46
05		GPA-1P6	$Q [l/s] = 674.6 \cdot h^{1.556}$	2.91	570	120	P46
06		GPA-1P7	$Q [l/s] = 1014.9 \cdot h^{1.556}$	4.4	890	130	P46
07		GPA-1P8	$Q [l/s] = 1368 \cdot h^{1.5638}$	5.8	1208	135	P46
08		GPA-1P9	$Q [l/s] = 2080.5 \cdot h^{1.5689}$	8.7	1850	150	P46
09	General PARSHALL flume					P46, P42	
10	PALMER-BOWLUS (D/2)					P46, P41	
11	PALMER-BOWLUS (D/3)					P46, P41	
12	PALMER-BOWLUS (Rectangular)					P46, P41, P42	
13	Khafagi Venturi					P46, P42	
14	Bottom-step weir					P46, P42	
15	Suppressed rectangular or BAZIN weir					P46, P41, P42	
16	Trapezoidal weir					P46, P41, P42	
17	Special trapezoidal (4:1) weir					P46, P42	
18	V-notch weir					P46, P42	
19	THOMSON (90°-notch) weir					P46	
20	Circular weir					P46, P41	
21	General flow formula: $Q[l/s] = 1000 \cdot P41 \cdot h^{P42}$ , h [m]					P46, P41, P42	

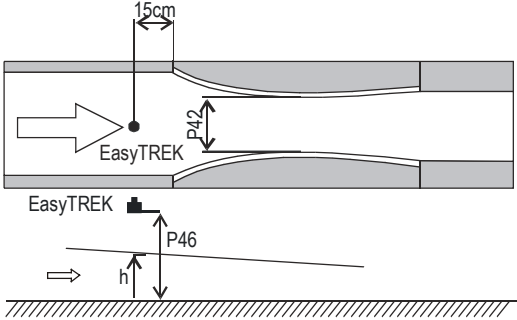
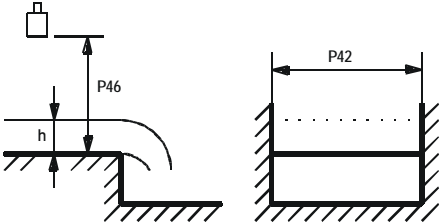
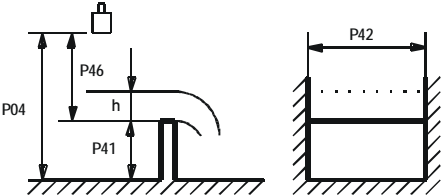

<p>P40= 10</p>	<p>Palmer-Bowlus (D/2) flume</p> <p><math>Q[m^3/s]= f(h1/P41)*P41^{2.5}</math>, where <math>h1[m]= h+(P41/10)</math></p> <p>P41 [m]</p>	
<p>P40= 11</p>	<p>Palmer-Bowlus (D/3) flume</p> <p><math>Q[m^3/s]= f(h1/P41)*P41^{2.5}</math>, where <math>h1[m]= h+(P41/10)</math></p> <p>P41 [m]</p>	
<p>P40= 12</p>	<p>Palmer-Bowlus (rectangular) flume</p> <p><math>Q[m^3/s]= C*P42*h^{1.5}</math>, where <math>C= f(P41/P42)</math></p> <p>P41 [m], P42 [m]</p>	

<p>P40= 13</p>	<p><b>Khafagi Venturi flume</b></p> <p><math>Q \text{ [m}^3\text{/s]} = 1,744 \cdot P42 \cdot h^{1,5} + 0,091 \cdot h^{2,5}</math></p> <p>P42 [m]</p> <p>h [m]</p>	
<p>P40= 14</p>	<p><b>Bottom step weir</b></p> <p><math>0,0005 &lt; Q \text{ [m}^3\text{/s]} &lt; 1</math></p> <p><math>0,3 &lt; P42 \text{ [m]} &lt; 15</math></p> <p><math>0,1 &lt; h \text{ [m]} &lt; 10</math></p> <p><math>Q \text{ [m}^3\text{/s]} = 5,073 \cdot P42 \cdot h^{1,5}</math></p> <p>Accuracy: <math>\pm 10\%</math></p>	<p>P40=14</p> 
<p>P40= 15</p>	<p><b>Suppressed rectangular or BAZIN weir</b></p> <p><math>0,001 &lt; Q \text{ [m}^3\text{/s]} &lt; 5</math></p> <p><math>0,15 &lt; P41 \text{ [m]} &lt; 0,8</math></p> <p><math>0,15 &lt; P42 \text{ [m]} &lt; 3</math></p> <p><math>0,015 &lt; h \text{ [m]} &lt; 0,8</math></p> <p><math>Q \text{ [m}^3\text{/s]} = 1,77738(1 + 0,1378h/P41) \cdot P42 \cdot (h + 0,0012)^{1,5}</math></p> <p>Accuracy: <math>\pm 1\%</math></p>	<p>P40=15</p> 

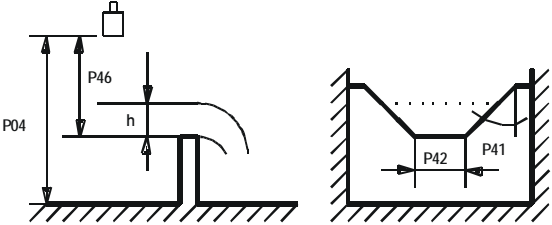
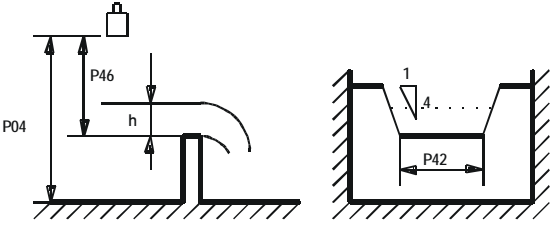
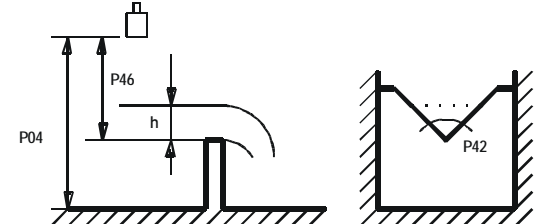
<p>P40= 16</p> <p>Trapezoidal weir</p> <p><math>0,0032 &lt; Q \text{ [m}^3/\text{s]} &lt; 82</math></p> <p><math>20 &lt; P41[^\circ] &lt; 100</math></p> <p><math>0,5 &lt; P42 \text{ [m]} &lt; 15</math></p> <p><math>0,1 &lt; h \text{ [m]} &lt; 2</math></p> <p><math>Q \text{ [m}^3/\text{s]} = 1,772 \cdot P42 \cdot h^{1,5} + 1,320 \cdot \text{tg}(P41/2) \cdot h^{2,47}</math></p> <p>Accuracy: <math>\pm 5\%</math></p>		<p>P40=16</p> 
<p>P40= 17</p> <p>Special trapezoidal (4:1) weir</p> <p><math>0,0018 &lt; Q \text{ [m}^3/\text{s]} &lt; 50</math></p> <p><math>0,3 &lt; P42 \text{ [m]} &lt; 10</math></p> <p><math>0,1 &lt; h \text{ [m]} &lt; 2</math></p> <p><math>Q \text{ [m}^3/\text{s]} = 1,866 \cdot P42 \cdot h^{1,5}</math></p> <p>Accuracy: <math>\pm 3\%</math></p>		<p>P40=17</p> 
<p>P40= 18</p> <p>V-notch weir</p> <p><math>0,0002 &lt; Q \text{ [m}^3/\text{s]} &lt; 1</math></p> <p><math>20 &lt; P42[^\circ] &lt; 100</math></p> <p><math>0,05 &lt; h \text{ [m]} &lt; 1</math></p> <p><math>Q \text{ [m}^3/\text{s]} = 1,320 \cdot \text{tg}(P42/2) \cdot h^{2,47}</math></p> <p>Accuracy: <math>\pm 3\%</math></p>		<p>P40=18</p> 

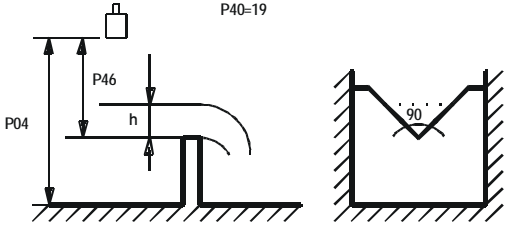
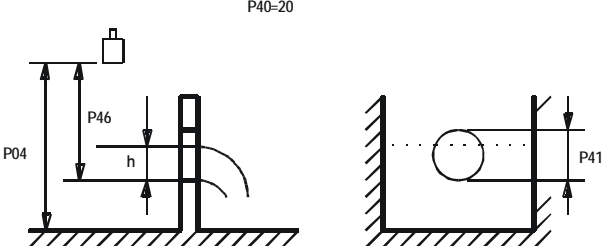
<p>P40= 19</p>	<p>THOMSON (90°-notch) weir  <math>0,0002 &lt; Q \text{ [m}^3/\text{s]} &lt; 1</math>  <math>0,05 &lt; h \text{ [m]} &lt; 1</math>  <math>Q[\text{m}^3/\text{s}] = 1,320 \cdot h^{2,47}</math>  Accuracy: <math>\pm 3\%</math></p>	
<p>P40= 20</p>	<p>Circular weir  <math>0,0003 &lt; Q \text{ [m}^3/\text{s]} &lt; 25</math>  <math>0,02 &lt; h \text{ [m]} &lt; 2</math>  <math>Q[\text{m}^3/\text{s}] = m \cdot b \cdot D^{2,5}</math>, where <math>b = f(h/D)</math>  <math>m = 0,555 + 0,041 \cdot h/P41 + (P41/(0,11 \cdot h))</math>  Accuracy: <math>\pm 5\%</math></p>	

P46: - - - - Distance at Q=0

FACTORY DEFAULT: 0

Distance between sensor surface and the level at which flow starts has to be entered in this parameter.

### 5.3.7. 32-POINT LINEARISATION

P47: --- a Linearisation

FACTORY DEFAULT: 0

Linearisation is the method of assigning requested (calibrated or calculated) level, volume or flow to values measured by the transmitter.

It can be used for instance if the sound velocity is not known (LEVEL $\Rightarrow$ LEVEL) or in the case of tank with other shape than under 6.4 or open channel other than under 6.5 (LEVEL  $\Rightarrow$  VOLUME or LEVEL  $\Rightarrow$  FLOW).

a	Linearisation
0	OFF (FACTORY DEFAULT)
1	ON

Conditions of correct programming of the data pairs

The table must always start with: L(1)= 0 and r(1)= value (assigned to 0 level)

The table must be ended either with the 32<sup>nd</sup> data pair i.e. j=32 or if the linearisation table contains less than 32 data-pairs j<32, it must be ended with a level value "0" e.g. L(j<32)= 0.

The EchoTREK will ignore data after recognising level value "0" with serial number other than "1".

If the above conditions are not met, error codes will be displayed (see chapter: Error Codes).

i	L (Left column) Level values measured	r (Right column) Value assigned to transmit
1	0	r(1)
2	L(2)	r(2)
	L(j)	r(i)
nn	L(nn)	r(nn)
nn+1	0	
32		

P48: Number of linearisation data pairs

Number of linearisation data pairs entered in the table.

### 5.3.8. INFORMATIONAL PARAMETERS (READ OUT PARAMETERS)

P60: - - - - Overall operating hours of the unit (h)

P61: - - - - Time elapsed after last switch-on (h)

P64: - - - - Actual temperature of the transducer (°C/°F)

Broken loop of the thermometer will be indicated by display of the Pt Error message initiated by a signal sent via HART. In this case the transmitter will perform temperature correction corresponding to 20°C.

P65: - - - - Maximum temperature of the transducer (°C/°F)

P66: - - - - Minimum temperature of the transducer (°C/°F)

P70: - - - - Number of Echoes / Echo Map

Amplitude and position of the echoes can also be read out.

P71: - - - - Distance of the of Measuring Window

P72 - - - - Amplitude of the selected echo [dB] <0

P73: Position of the selected echo (time) :(ms)[ms]

P74: Signal To Noise Ratio

Ratio	Measurement conditions
Over 70	Excellent
Between 70 and 30	Good
Under 30	Unreliable

P75: - - - - Blocking Distance

The actual close-end blocking distance will be displayed (provided automatic blocking was selected in P05).

### **5.3.9. ADDITIONAL PARAMETERS OF THE FLOW METERING**

P76: ---- Head of flow (LEV) (Read only parameter) (LEV)

The Headwater value can be checked here. This is the “h” value in the formula for flow calculation.

P77: ---- TOT1 volume flow totalised (resettable)

P78: ---- TOT2 volume flow totalised (non-resettable)

### **5.3.10. OTHER PARAMETERS**

P96: ---- Software code 1 (Read only parameter)

P97: ---- Software code 2 (Read only parameter)

P98: ---- Hardware code (Read only parameter)

P99: dcba Access lock by secret code

The purpose of this feature is to provide protection against accidental programming or intentional reprogramming of parameters by a person not entitled to do so. The secret code can be any value other than 0000. Setting a secret code will automatically be activated when the EasyTREK is returned to the Measurement Mode. In order to program locked device the secret code should be entered first in P99. Thus for entering a new code or erasing the old one the knowledge of the previous code is necessary.

## **6. MAINTENANCE AND REPAIR**

EasyTREK SP units do not require maintenance on a regular basis.

The need for cleaning of the sensor head may occur. Cleaning should be performed by utmost care where scraping or denting of the transducer have to be avoided.

Repair under or after the guarantee period should only be carried out by Nivelco. Devices for repair should only be returned duly cleaned and disinfected.

## 7. ERROR CODES

Error Code	Error description	Causes and solutions
1	Memory error	Contact local agent
No Echo	Echo loss	See Action 5 and 6
3	Hardware error	Contact local agent
4	Display overflow	Check settings
5	Sensor error or improper installation/mounting, level in the dead band	Verify sensor for correct operation and check for correct mounting according to the User's Manual
6	The measurement is at the reliability threshold	Better location should be found.
7	No signal received within the measuring range specified in P04 and P05	Check programming, also look for installation mistake
12	Linearisation table error: both L(1) and L(2) are zero (no valid data-pairs)	See "Linearisation" Section
13	Linearisation table error: same L(i) data is given twice in the table	See "Linearisation" Section
14	Linearisation table error: the r(i) values are not monotone increasing	See "Linearisation" Section"
15	Linearisation table error: measured Level is higher than the last Volume or Flow data-pair	See "Linearisation" Section"
16	The check sum of the program is wrong	Contact local agent
17	Parameter consistency failure	Check programming
18	Hardware failure	Contact local agent

## 8. PARAMETER TABLE

Par.	Page	Description	Value				Par.	Page	Description	Value			
			d	c	b	a				d	c	b	a
P00	14	Application/Engineering Units					P28	23	Echo loss indication				
P01	15	Measurement Mode					P29	24	Blocking out a disturbing object				
P02	17	Calculation units					P30		-				
P03		-					P31	24	Sound velocity values in different gases				
P04	17	Maximum Measuring Distance					P32	24	Specific gravity				
P05	18	Minimum Measuring Distance					P33		-				
P06	19	Far End Blocking					P34		-				
P07		-					P35		-				
P08		-					P36		-				
P09		-					P37		-				
P10	20	Transmitted value assigned to „4 mA“					P38		-				
P11	20	Transmitted value assigned to „20 mA“					P39		-				
P12	20	“Error” indication by the current output					P40	25	Selection of tank shape/ open channel				
P13		-					P41	25	Dimensions of tank / Open Channel				
P14		-					P42	25	Dimensions of tank / Open Channel				
P15		-					P43	25	Dimensions of tank / Open Channel				
P16		-					P44	25	Dimensions of tank / Open Channel				
P17		-					P45	25	Dimensions of tank / Open Channel				
P18		-					P46		Level pertaining to flow Q= 0				
P19		-					P47	32	Linearisation				
P20	21	Damping					P48	32	Linearisation table				
P21		-					P49		-				
P22	21	Dome top tank compensation					P50		-				
P23		-					P51		-				
P24	21	Target tracking speed					P52		-				
P25	22	Selection of Echo in the measuring window					P53		-				
P26	22	Level elevation rate					P54		-				
P27	22	Level descent rate					P55		-				

Par.	Page	Description	Value			
			d	c	b	a
P56		–				
P57		–				
P58		–				
P59		–				
P60	33	Overall operating hours of the unit				
P61	33	Time elapsed after last switch-on				
P62		–				
P63		–				
P64	33	Actual temperature of the transducer				
P65	33	Maximum temperature of the transducer				
P66	33	Minimum temperature of the transducer				
P67		–				
P68		–				
P69		–				
P70	33	Echo Map				
P71	33	Position of the measuring window				
P72	33	Amplitude of the selected echo				
P73	33	Position of the selected echo				
P74	33	Signal / noise ratio				
P75	33	Blocking distance value				
P76	34	Water head of the flow				
P77	34	TOT1 volume flow totalised				

Par.	Page	Description	Value			
			d	c	b	a
P78	34	TOT2 volume flow totalised				
P79		–				
P80		–				
P81		–				
P82		–				
P83		–				
P84		–				
P85		–				
P86		–				
P87		–				
P88		–				
P89		–				
P90		–				
P91		–				
P92		–				
P93		–				
P94		–				
P95		–				
P96	34	Software code 1				
P97	34	Software code 2				
P98	34	Hardware code				
P99	34	Access lock by secret code				

## 9. SOUND VELOCITY VALUES IN DIFFERENT GASES

The following table contains the sound velocity values of various gases measured at 20°C.

Gases	Formula	Sound Velocity (m/s)
Acetaldehyde	C <sub>2</sub> H <sub>4</sub> O	252,8
Acetylene	C <sub>2</sub> H <sub>2</sub>	340,8
Ammonia	NH <sub>3</sub>	429,9
Argon	Ar	319,1
Benzene	C <sub>6</sub> H <sub>6</sub>	183,4
Carbon dioxide	CO <sub>2</sub>	268,3
Carbon monoxide	CO	349,2
Carbon tetrachloride	CCl <sub>4</sub>	150,2
Chlorine	Cl <sub>2</sub>	212,7
Dimethyl ether	CH <sub>3</sub> OCH <sub>3</sub>	213,4
Ethane	C <sub>2</sub> H <sub>6</sub>	327,4
Sulphur hexafluoride	SF <sub>6</sub>	137,8

Gases	Formula	Sound Velocity (m/s)
Ethanol	C <sub>2</sub> H <sub>3</sub> OH	267,3
Ethylene	C <sub>2</sub> H <sub>4</sub>	329,4
Helium	He	994,5
Hydrogen sulphide	H <sub>2</sub> S	321,1
Methane	CH <sub>4</sub>	445,5
Methanol	CH <sub>3</sub> OH	347
Neon	Ne	449,6
Nitrogen	N <sub>2</sub>	349,1
Nitrogen monoxide	NO	346
Oxygen	O <sub>2</sub>	328,6
Propane	C <sub>3</sub> H <sub>8</sub>	246,5

---

spa3804a0600p\_02

December 2005

Nivelco reserves the right to change technical specifications without notice.