

2.5 DIMENSIONS

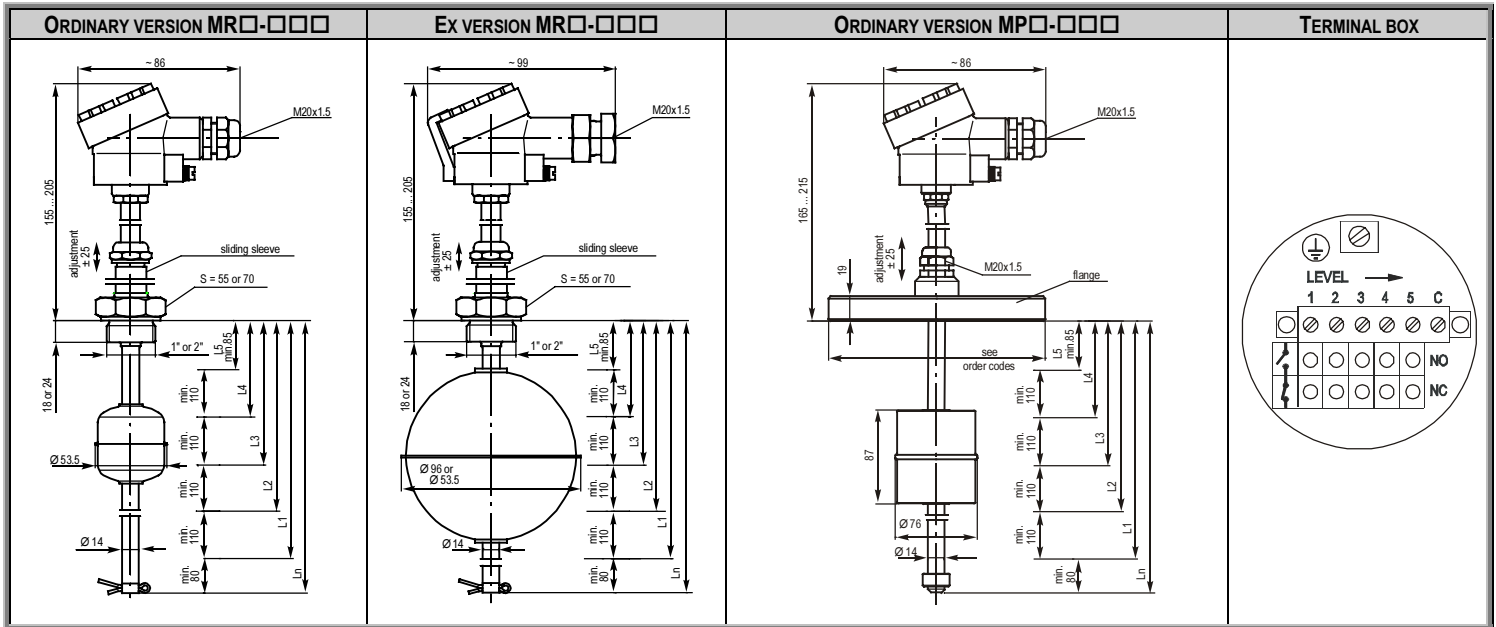

3. INSTALLATION

For mechanical installation 1", 2" BSP or NPT threads can be used. Minimal gap diameter for the float is $\varnothing 55$ mm. Use the M20x1.5 cable gland for electrical connection. The only version that can be installed without removing the float from the shaft and reassembling it from the inside of the tank is the version with 2" (BSP or NPT) process connection. If protection tube is used the minimum tube diameter should be $\varnothing 75$ mm (for insertion length < 1.5 m and $\varnothing 95$ mm for insertion length > 1.5 m). When using a $\varnothing 90$ mm float the tube diameter should be min. $\varnothing 130$ mm.

WARNING!

The sliding sleeve must not be loosened in tanks under pressure. The unit should be mounted in vertical position via its process connection and handled with care to avoid any damage or bend of the protection tube during transportation or installation.

4. WIRING

Depending on the grounding system either the inner or the outer grounding terminal should be connected to the EP network.

STANDARD MODEL

Remove the cover. Feed the electrical cables through the cable gland and connect them in accordance with the sketch on the cover where the (NO/NC) states of the relays are marked. The terminal of the lowest switch point has to be number 1. „C“ is common terminal.

The cross section of the connecting cable has to be between 0.5 and 2.5 mm².

EX VERSION

Remove the retainer clamp and screw the cover off. Feed the electrical cables through the cable gland and connect them in accordance with the sketch on the cover where the (NO/NC) states of the relays are marked.

Connect the grounding screw to the grounding system. Place the cover back and fasten the retainer clamp by setting it into one of the notches of the cover.

5. SET UP, ADJUSTMENT

After screwing in and before tightening the sliding sleeve the direction of the cable gland and the position of the reed-relay set can be adjusted.

An open-end wrench should be used when loosening or screwing tight the sliding sleeve. The position of the reed-relay set can be vertically adjusted by a max. of ± 25 mm.

5.1 SPECIAL CONDITIONS OF THE EX APPLICATION

The apparatus met the requirements specified for mechanical strength with reduced impact energy ($4 J = 1 kg; 0.4 m$).

On the basis of the above the place and way of installation should guarantee the protection of the unit against external mechanical impacts during service.

6. MAINTENANCE, REPAIR

The instrument does not require regular maintenance. In some instances, however, the probe may need occasional cleaning to remove surface deposits. This must be carried out gently, without harming the probe.

Repairs during or beyond the guarantee period are carried out solely by the manufacturer. Equipments sent back for repair should be cleaned or sterilised by the User. The User must declare that the above has been carried out.

7. STORAGE CONDITIONS

Ambient temperature: $-25^{\circ}C$ to $+60^{\circ}C$
Relative humidity: max. 98 %

8. WARRANTY

All Nivelco products are warranted free of defects in materials or workmanship for a period of two years from the date of purchase, as indicated in the Certificate of Warranty.

mra1053a0600h_07
January, 2007

Nivelco reserves the right to change technical specifications without notice.