

Thank you for choosing a NIVELCO instrument
We are sure that you will be satisfied with it throughout its use

1. OPERATION

The NIVOSWITCH is a mechanical resonance system excited and kept in resonance by an electronic circuitry. The process liquid, when reaching the tines of vibration fork, modifies the vibration. The NIVOSWITCH can cover the majority of industrial liquid level detecting applications including installation in explosion hazardous area. Overfill or dry run protection as well as pump control is made possible with the versatile level switch.

2. TECHNICAL DATA

2.1 GENERAL DATA

R 400 / R 400 Ex	
Maximum pressure	40 bar, 6 bar, for PP flange see derating diagrams
Probe length	0.69 to 3 m
Material of the wetted parts	DIN 1.4571, Halar (ECTFE) coated
Liquid temperature range	see table in 5.1 and diagrams
Ambient temperature range	see table in 5.1 and diagrams
Liquid density	$\geq 0.7 \text{ kg/dm}^3$
Liquid viscosity	$\leq 10000 \text{ mm}^2/\text{s (cSt)}$
Response time	When immersed: 0.5 sec When free: $\leq 1 \text{ s}$ see response time diagram
Output mode indication	Bicolour (LED)
Operation test	Output can be changed by test magnet

USER'S MANUAL



2.2 2-wire DC, NORMAL AND EX APPROVED VERSION

VERSION	2-wire DC	
	R□□-4□□-6 R□□-4□□-8 Ex	R□□-4□□-7 R□□-4□□-9 Ex
Electric connections (wire cross section)	Connector	Integral cable (2 x 0.5 mm ²)
Ingress Protection	IP 65	IP 68
Output	DC current change: When free: $9 \pm 1 \text{ mA}$; When immersed: $14 \pm 1 \text{ mA}$	
Consumption	$< 0.5 \text{ W}$	
Power supply (U)	15 ... 27 V DC Provided by the PKK-312-8 Ex remote switching unit for the Ex version	
Setting operating mode	By switch on the remote switching unit (low fail-safe, high fail-safe)	
Electrical protection	Class III	
Ex protection mark	 II 1 / 2 G EEx ia IIC T6 ... T4	
Intrinsically safe data	U < 28 V, I < 100 mA P < 1,4 W, Ceq < 7 nF Leq ≈ 0 For temperature classes see 5.1.	



Manufacturer:
NIVELCO Process Control Co.
H-1043 Budapest, Dugonics U. 11.
Phone: (36-1) 369-7575 ♦ Fax: (36-1) 369-8585
e-mail: sales@nivelco.com ♦ www.nivelco.com

2.3 2-WIRE AC AND 3-WIRE DC VERSIONS, TO DRIVE RELAYS, PLC-S

VERSION	2 wire AC		3 wire DC	
	R□□-4□□-1	R□□-4□□-2	R□□-4□□-3	R□□-4□□-4
Electric connections (wire cross section)	Connector	Integral cable (4 x 0.75 mm ²) max length 30 m	Connector	Integral cable (5 x 0.5 mm ²) max length 30 m
Mechanical protection	IP 65	IP 68	IP 65	IP 68
High/low mode setting	Connection within connector	Wire selectable	switch selectable	Wire selectable
Output	2-wire AC, for serial connection		Field selectable, PNP/NPN transistor switch	Field selectable, galvanically isolated PNP/NPN transistor switch
Output protection	—		Reverse polarity, overcurrent and short circuit protection	
Supply voltage	20 ... 255 V AC, 50/60 Hz		12 ... 55 V DC	
Consumption	Depending on load		$< 0.6 \text{ W}$	
Voltage drop in switched-on state	$< 10.5 \text{ V}$		$< 4.5 \text{ V}$	
Electrical protection	Class I		Class III	
Current load	max. continuous	350 mA AC 13	$I_{\text{max}} = 350 \text{ mA DC} / U_{\text{max}} = 55 \text{ V DC}$	
	min. continuous	10 mA / 255 V, 25 mA / 24 V	—	
	max. impulse	1.5 A / 40 ms	—	
Residual current (in switched off state)	$< 6 \text{ mA}$		$< 100 \mu\text{A}$	

2.4. ACCESSORIES

- User's manual,
- Guarantee sheet,
- Declaration of conformity,
- Magnetic screw driver RPS-101 (optional).
- Sealing ring (2 mm thick KLINGER OILIT).
- Sliding sleeve RPH-112 (optional).

2.5. ORDER CODES

NIVOSWITCH R □ □ - 4 □ □ - □ *

FORK	CODE	CONNECTIONS	CODE	LENGTH	CODE	OUTPUT	CODE
ECTFE coated	A	1" BSP thread	M	SHORTY (69 mm)	00	2-wire AC with connector	1
Standard	C	1" NPT thread	P	Standard (125 mm)	01	2-wire AC with cable	2
Highly polished	G	DIN DN50PN40 st.st flange	G	0.2 to 3 m	02...30	3-wire PNP / NPN with connector	3
		2" ANSI st.st. flange	B			3-wire PNP / NPN with cable	4
		50A JIS st.st flange	K			2-wire DC with connector	6
		DIN DN50 PN16 PP flange	F**			2-wire DC with cable	7
		2" ANSI PP flange	A**			2-wire Ex with connector	8
		50A JIS PP flange	J**			2-wire Ex with cable	9
		1½" Triclamp (ISO2852)	T				
		2" Triclamp (ISO2852)	R				
		DN40 Pipe coupling (DIN11851)	D				
		DN50 Pipe coupling (DIN11851)	E				

* Ex version with Ex mark
** Only for non-Ex version

Flanged versions as standard come with flanges screwed on the 1" process connection.

2.6. DERATING DIAGRAMS

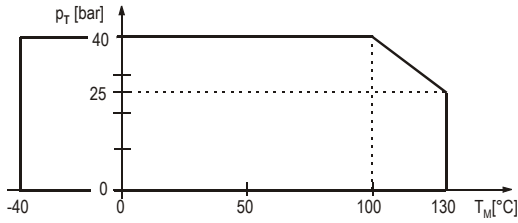

Pressure p_T version $[T_M]$ for all models (except PP flanged)



For 3-wire DC models $[I_L]$ load current

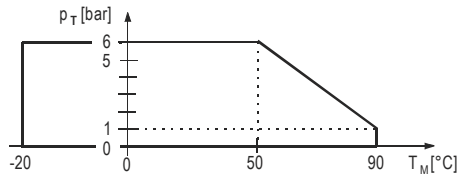

For models with Polypropylene flange p_T =process pressure
 T_M =medium temperature

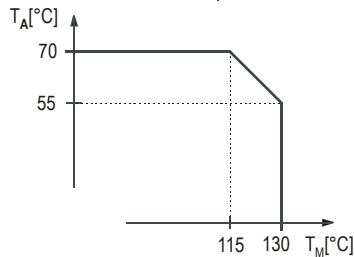

For 2-wire AC models $[T_A]$ ambient temperature $[T_M]$ medium temperature

2.7. RESPONSE TIME DIAGRAM WHEN GETTING FREE

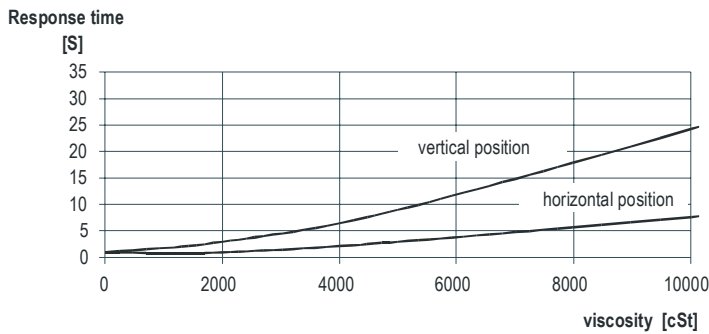

2.8 DIMENSIONS

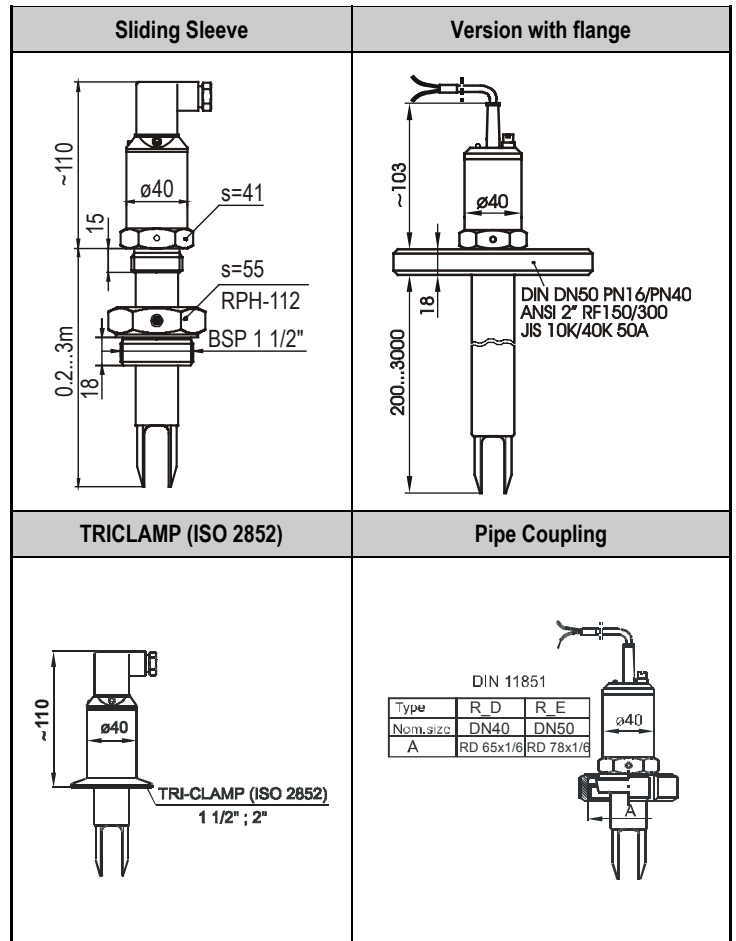
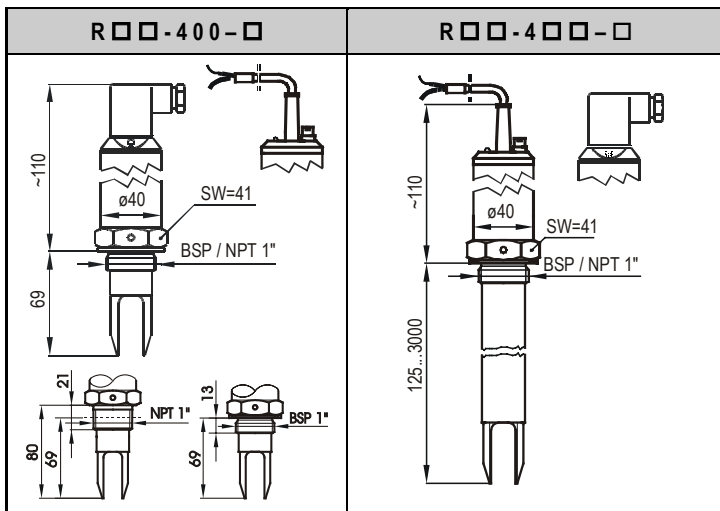

2.9 MATERIALS

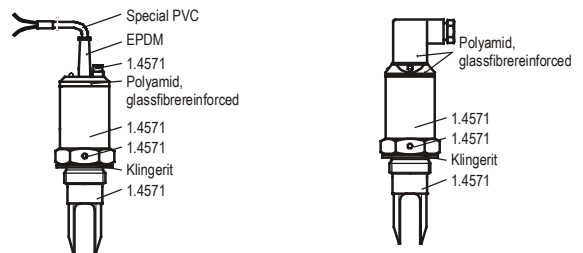

3. INSTALLATION

Prevent the device from any mechanical damage.

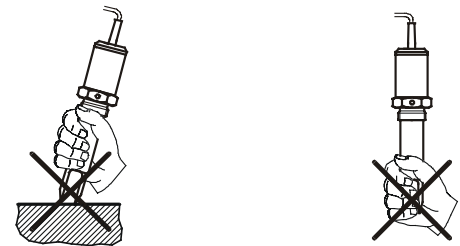
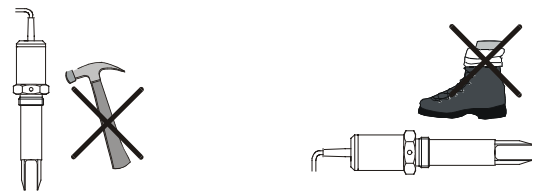

For positioning the fork-tines, use the marking on the hexagonal neck.

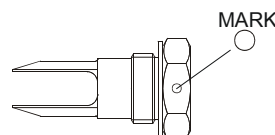

- Use a TEFLON (PTFE) tape to aid the positioning of the fork-tine
- If the fork-tine position is irrelevant, use the sealing ring provided

Low viscosity liquids

On applications, where the fork-tines are easily freed from the process medium, any of the mountings shown to the right is possible.

High viscosity liquids

On applications, where the fork-tines are not freed easily from the process medium, the horizontal mounting is recommended.

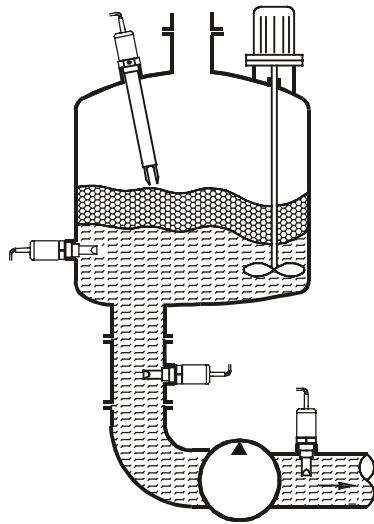

Installation options

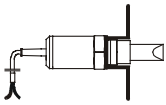

Threaded version

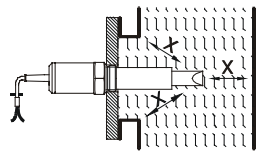

Critical distances ($x_{min} > 5\text{ mm}$)



For pipe mounting, fork-tines must be parallel to the direction of flow

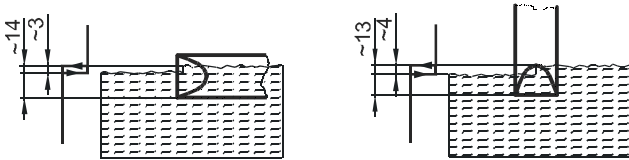

Switching point and switch differential for water at 25 °C

Switching point as well as the switch differential depends on liquid density and mounting position

4. ELECTRICAL CONNECTIONS

4.1. 2 WIRE AC VERSIONS R □ □ - 4 □ □ - 1 connector
R □ □ - 4 □ □ - 2 cable

DO NOT POWER UP THE DEVICE WITHOUT A LOAD CONNECTED IN SERIES WITH THE UNIT AND WITHOUT GROUNDING IT

4.1.1. Connector version R □ □ - 4 □ □ - 1

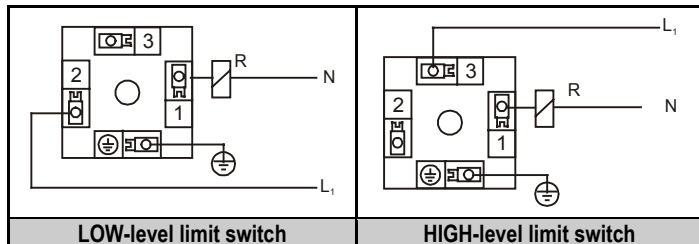

Terminal block cover can be rotated in 90° steps to ensure appropriate cable positioning

4.1.2. Integral cable version R □ □ - 4 □ □ - 2

This version is with 4 wire cable equipped. Only one of the black and brown wires is used, dependent on the operating mode (High or Low)

Provide also a terminal block connection for the unused wire.

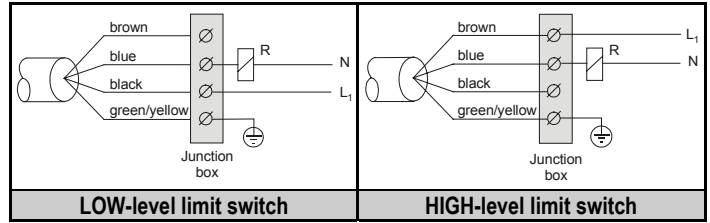

4.2. 3 WIRE DC VERSIONS

R □ □ - 4 □ □ - 3
R □ □ - 4 □ □ - 4

In case of overload caused by short circuit, transistor will switch on and off, and LED will start to blink.

4.2.1. Connector version R □ □ - 4 □ □ - 3

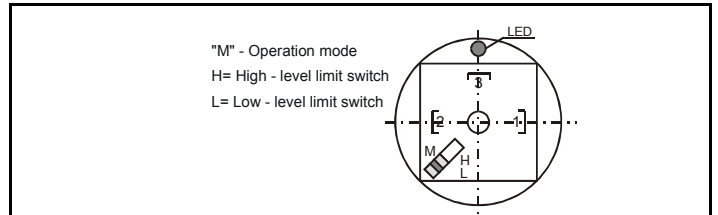

4.2.1.1. Wiring diagram for 3 wire DC version with connector in case of relay application

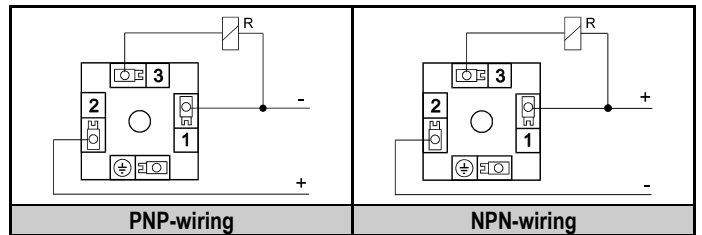

Terminal block cover can be rotated in 90° steps to ensure appropriate cable positioning

4.2.1.2. Wiring diagram for 3-wire DC version with connector for PLC application

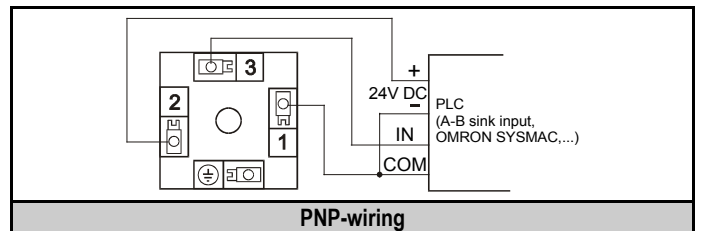

4.2.2. Integral cable version

R □ □ - 4 □ □ - 4

4.2.2.1. Relay application

PNP mode

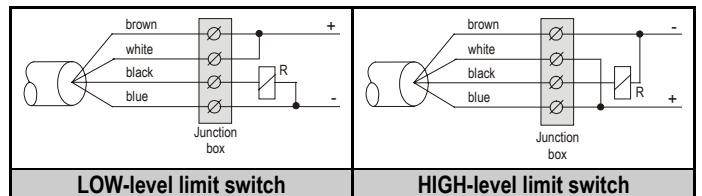

NPN mode

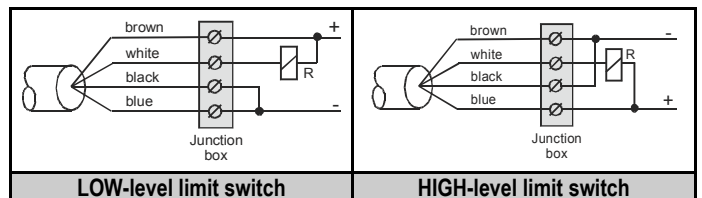

4.2.2.2. PLC applications (A-B sink input, OMRON SYSMAC...)

PNP mode

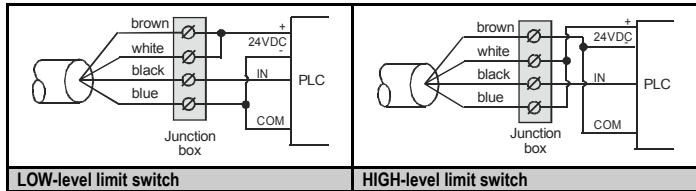

4.3. 2 wire DC versions

STANDARD OR EX

4.3.1. Connector version

R □ □ - 4 □ □ - 6
R □ □ - 4 □ □ - 8 Ex

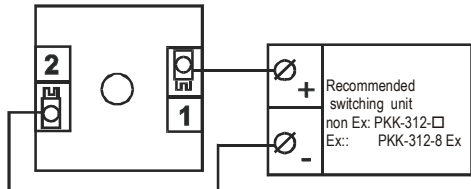

4.3.2. Integral cable version

R □ □ - 4 □ □ - 7
R □ □ - 4 □ □ - 9 Ex

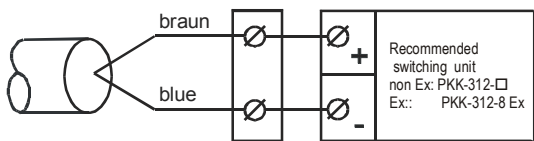

5. ADJUSTMENT

Check connecting of the wires and position of the mode of operation switch (if there is). After connection and power up the tuning fork is operational.

Operating diagram of the NIVOSWITCH (except 2-wire DC versions)

Power supply	Fork	Operating mode	LED	Output
ON	Immersed	HIGH-level limit switch	RED	OFF
		LOW-level limit switch	GREEN	ON
	Free	HIGH-level limit switch	GREEN	ON
		LOW-level limit switch	RED	OFF
FAILS	Free or immersed	HIGH or LOW	NOT LIT	OFF

Operating diagram of the 2-wire DC version

Fork	LED	Output
Immersed	RED	14 ± 1 mA
Free	GREEN	9 ± 1 mA

OPERATION TEST

Correct operation of the switching circuit of an installed device can be tested with the optional test magnet (RPS-101).

Moving the test magnet in front of the marking on the cover of the housing the device must perform a switching (LED changes colour).

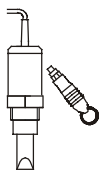

5.1. APPLYING Ex APPROVED MODELS

Applying Ex approved models take into consideration the table of allowed temperatures listed below

Temperature classification	T6	T5	T4
T _{Ambient}	60 °C	70 °C	60 °C
T _{Medium}	80 °C	70 °C	95 °C

Table of possible temperatures

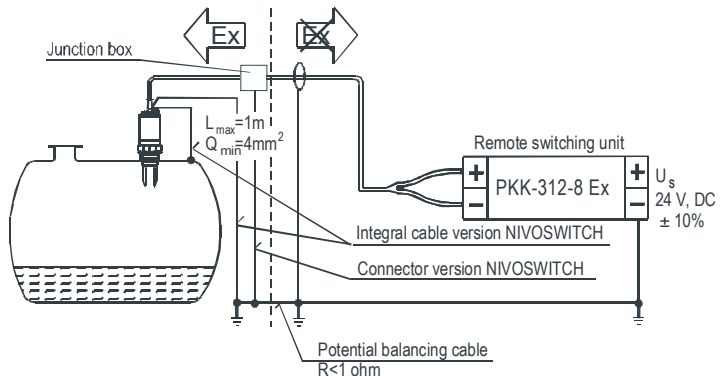

CONDITIONS OF SAFE OPERATION

- The vibration fork level switch has to be supplied by a certified intrinsically safe circuit with maximum parameters only:
 $U_0 = 28 \text{ V}$
 $I_0 = 100 \text{ mA}$
 $P_0 = 1.4 \text{ W}$
- For installation of version R □ □ - 4 □ □ - 9 Ex with integrated cable, there has to be a suitable connection box near the level switch.
- It is allowed for the vibration fork to get in contact with the liquid only; the installation has to guarantee that the housing (head) is outside the liquid.
- The level switch has to be connected to the local equipotential bonding.
- To avoid electrostatic ignition danger, the coated version type RA □ - 4 □ □ - Ex is allowed for substances with explosion group IIA or IIE only.

6. MAINTENANCE, REPAIR

The NIVOSWITCH R-400 does not require routine maintenance. In some instances, however, the sensor probe may need occasional cleaning to remove surface deposits. This must be carried out gently, without harming the vibrating section of the vibrating fork.

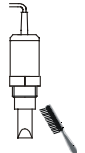

7. STORAGE CONDITIONS

Ambient temperature: -35 to +60 °C
 Relative humidity: max. 98 %

8. WARRANTY

All NIVELCO products are warranted to be free from defects according to the Warranty Sheet, within two (2) years from the date of purchase.

rcm4004a0600h_06
 April, 2004

Nivelco reserves the right to change technical specifications without notice.