



UNICONT

PDF – loop indicator and
converter to HART

INSTALLATION AND PROGRAMMING MANUAL

3rd Edition

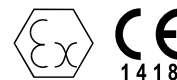

Manufacturer:

NIVELCO Process Control Co.

1043 Budapest, Dugonics u. 11.

Tel: (36-1) 889-0100 ♦ Fax: (36-1) 889-0200

e-mail: sales@nivelco.com ♦ www.nivelco.com

CONTENTS

1. INTRODUCTION	5
2. ORDER CODES	5
3. TECHNICAL DATA	6
3.1 GENERAL DATA	6
3.2 DIMENSIONS	7
3.3 ACCESSORIES	8
4. INSTALLATION AND ELECTRIC CONNECTION	9
4.1 WIRING	9
4.2 SAFETY REGULATIONS FOR THE EEX CERTIFIED UNITS	12
5. PUTTING INTO OPERATION, PROGRAMMING	12
5.1 DEFAULT	13
5.2 DISPLAY OF THE SAP-202 AND KEYS OF THE UNIT	14
5.3 PROGRAMMING	14
5.3.1 STEPS OF PROGRAMMING	15
5.3.2 PARAMETERS – DESCRIPTION AND PROGRAMMING	17
5.4 ERROR INDICATIONS	23
5.4.1 VALID LED IS BLINKING AND A MESSAGE OF ERRX APPEARS ON THE DISPLAY	23
5.4.2 VALID LED AND THE DISPLAYED VALUE IS BLINKING	23
5.4.3 ERROR INDICATION ON THE OUTPUT CURRENT (FOR 3-WIRE MODELS ONLY)	23
6. MAINTENANCE AND REPAIR	24
7. STORAGE	24

*Thank you for choosing NIVELCO instrument
We are sure that you will be satisfied throughout its use!*

1. INTRODUCTION

The UNICONT PDF-4/501 and PDF-401-6/A/C Ex devices are 2-wire on-site indicators that can be inserted into a 4 ... 20 mA current loop without the need for additional power supply. Since the displayed value is proportional to the input, the units are suitable for indication of temperature, pressure, level, etc. values, the information carried by the loop current. The customer can program the engineering units and the indication range.

The HART capable Unicont P□F-4/501-4 and P□F-401/8/B/D Ex 3-wire process indicators require additional power supply. Besides displaying the loop current or the process values, these units convert input current to HART signals and so enable devices that have analogue outputs only to be integrated into HART multidrop systems. The ratio between the input and output current can be programmed.

The intelligent electronics and HART communication enables versatile signal processing and remote programming. The software uses the Universal HART commands No. 1-3, 6, 7, 11-18 and device specific commands No128-132, 135 and 139 of the HART Revision 5.

Robust enclosure makes applications under harsh conditions also possible. Explosion proof versions are available for hazardous environments.

2. ORDER CODES

UNICONT P □ F. - □ 0 1 - □ *

FUNCTION	CODE
With display	D
Without display	T

HOUSING	CODE
Aluminium	4
Plastic	5

OUTPUT / EX	CODE
Display	2
4 ... 20 mA + HART*	4
Display / EEx ia	6
4 ... 20 mA + HART / EEx ia*	8
Display / EEx d	A
4 ... 20 mA + HART / Eex* d	B
Display / EEx d ia*	C
4 ... 20 mA + HART / EEx d ia*	D

Not all combinations are possible!

Ex certified units come with aluminium housing only.

* The order code of an Ex version should end in "Ex"

The models with display outputs are 2-wire units.

3. TECHNICAL DATA

3.1 GENERAL DATA

TYPE	PDF- □01-2 PDF-401-6 Ex PDF-401-A Ex PDF-401-C Ex	□□F- □01-4 □□F-401-8 Ex □□F-401-B Ex □□F-401-D Ex
Powering	2-wire	3-wire
Input	Current loop	
Range	3.6 ... 22 mA	0 ... 22 mA
Display/indication	6-digit LCD, engineering units and bargraph	
Range of displayed value	-9999 ... 29999	
Engineering units (programmable)	mA, °C, °F, %, m, cm, in, ft, l, m ³ , gal, ft ³	
Displayed process values (programmable)	DIST (distance), LEV (level), VOL (volume/content)	
Ambient temperature	Ordinary and EEx ia devices: -40°C...+70°C, with display module: -25°C...+70°C ; EEx d és EEx d ia devices: -40°C...+70°C, with display module: -20°C...+70°C	
Accuracy	± 0,1 % for displayed values over 10000	
Temperature coefficient	± 0.05 % / 10°K	
Output	----	4...20 mA and/or HART for 4...20mA current limit values: 3.9...20.5 mA terminal resistor for HART R _{min} = 250 Ω
Error indication on the current output	----	Output = 3.8 or 22 mA
Voltage at the terminals	----	10 V...36 V*
Load resistance	----	R _L ≤ (U _t -10V) / 0,022A (U _t supply voltage)
Voltage drop	< 1.6 V	< 1 V
Overvoltage capability	150 mA	200 mA
Damping	3 s, 5 s, 10 s or 20 s	
Electric protection	Class III	
Ingress protection	IP67	
Electric connection	Through M20x1.5 cable gland, shielded, multistrand, twisted cable of Ø 6...12 mm (or Ø 7...13mm for EEx- ia, and 8...12mm for EEx-d) wire cross section 0,25 ... 1,5 mm ²	
Housing	Paint coated aluminium (öAlSi12) or PBT glass fibre reinforced	
Mass 1	Aluminium housing appr. 0.9 kg, plastic housing appr. 0.55 kg	

*For □□F-401-8Ex and □□F-401-DEX units see table of 'Additional data for Ex certified versions'

ADDITIONAL DATA FOR EX CERTIFIED VERSIONS

TYPE	PDF – 401 – 6 Ex	PDF – 401 – A Ex	PDF – 401 – C Ex
Ex protection	Intrinsically safe	Flame proof	Flame proof, intrinsically safe
Ex marking	⊕ II 1 G EEx ia IIC T6	⊕ II 2 G EEx d IIB T6	⊕ II 1/2 G EEx d ia IIB T6
Intrinsical safety data	$U_i = 2,1\text{ V}$ $I_i = 140\text{ mA}$ $C_i \approx 0\text{ nF}$ $L_i < 200\ \mu\text{H}$		$U_i = 2,1\text{ V}$ $I_i = 140\text{ mA}$ $C_i \approx 0\text{ nF}$ $L_i < 200\ \mu\text{H}$
Cable gland	Metal M 20 x1.5 cable diameter 7...13 mm	Metal M 20 x1,5 cable diameter: 8 ... 12 mm	
Housing	Paint coated aluminium		
TYPE	P□F – 401 – 8 Ex	P□F – 401 – B Ex	P□F – 401 – D Ex
Ex protection	Intrinsically safe	Flame proof	Flame proof, intrinsically safe
Ex marking	⊕ II 1 G EEx ia IIB T6	⊕ II 2 G EEx d IIB T6	⊕ II 1/2 G EEx d ia IIB T6
Intrinsical safety data	$U_i = 30\text{ V}$ $I_i = 140\text{ mA}$ $P_i = 1,0\text{ W}$ $C_i < 20\text{ nF}$ $L_i < 200\ \mu\text{H}$	-	$U_i = 30\text{ V}$ $I_i = 140\text{ mA}$ $P_i = 1,0\text{ W}$ $C_i < 20\text{ nF}$ $L_i < 200\ \mu\text{H}$
Cable gland	Metal M 20 x1,5 cable diameter 7...13 mm	Metal M 20 x1,5 cable diameter: 8 ... 12 mm	
Housing	Paint coated aluminium		

3.2 DIMENSIONS

Dimensions in mm

Figure 1.

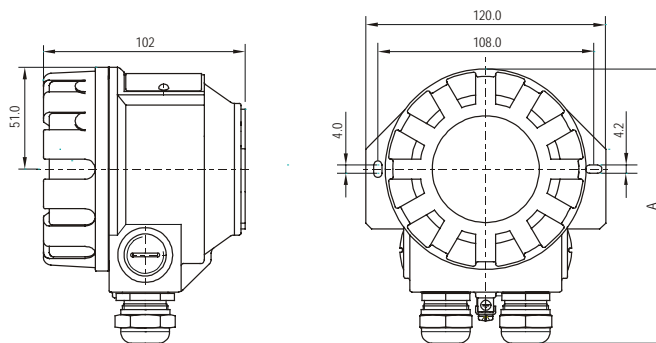

Type	A
Ordinary, EEx ia	~137mm
EEx d, EEx d ia	~145mm

3.3 ACCESSORIES

Ordinary, EEx ia:

- Installation and programming manual
- Warranty Card
- Declaration of Conformity
- 2 cable glands
- Sticker set of engineering units

EEx d, EEx d ia:

- Installation and programming manual
- Warranty Card
- Declaration of Conformity
- Sticker set of engineering units

HART capable units

- EView Light software on CD-ROM (in addition)

4. INSTALLATION AND ELECTRIC CONNECTION

The devices are suitable for working in closed areas or they can be used in open-air applications, too. Installation location should be selected so that proper space is available for handling, programming and checking the display. Mounting the units on the wall or to a support can be done with using 2pcs of M4 nuts.

4.1 WIRING

- 2-wire indicators are used in 4... 20 mA current loops. They do not require separate power supply.
- 3-wire devices are powered with 10...36 VDC through the output.
- Current values on the terminals should not exceed overload capability limits. *
- Wiring should be made with shielded cable, specified under 'Technical Data'.
- After removal of the cover of the housing and the display module the screw terminals can be accessed. ** Cover of the flame proof housing can be removed after unhooking the safety clamp. Device should not be under power.
- After wiring and programming the cover should be screwed to tightness of the sealing. The safety clamp of the flameproof cover should be fastened.

* Max. 150 mA for 2-wire and max. 200 mA for 3-wires devices.

** Devices should be grounded by using their grounding screws.



The unit may be damaged by electrostatic discharge (EDS) at its terminal, thus the precautions commonly used to avoid electrostatic discharge e.g. by touching a properly grounded point before removing the cover of the enclosure should be applied.

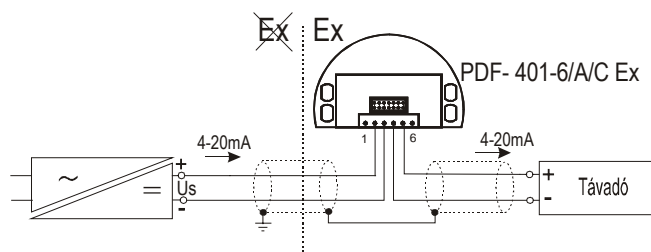

Figure 2. Wiring of a 2-wire Unicont in the current loop of a transmitter

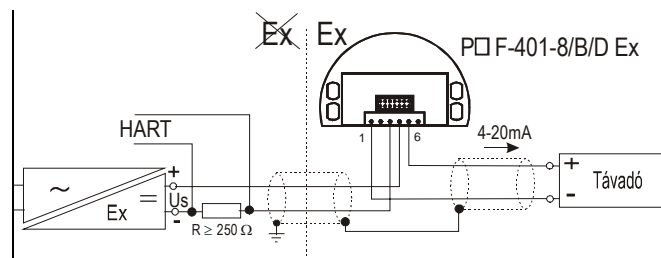

Figure 3. Wiring of a HART capable (3-wire) Unicont in the current loop of a transmitter

Shielding should be grounded at one point.

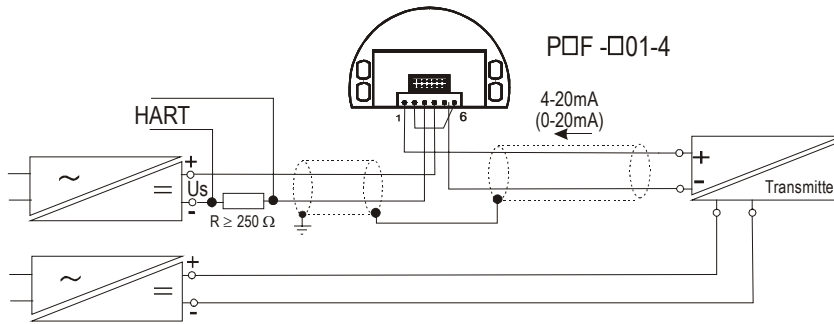

Figure 4. Wiring of a HART capable (3-wire) Unicont in the current loop of a 4-wire transmitter.

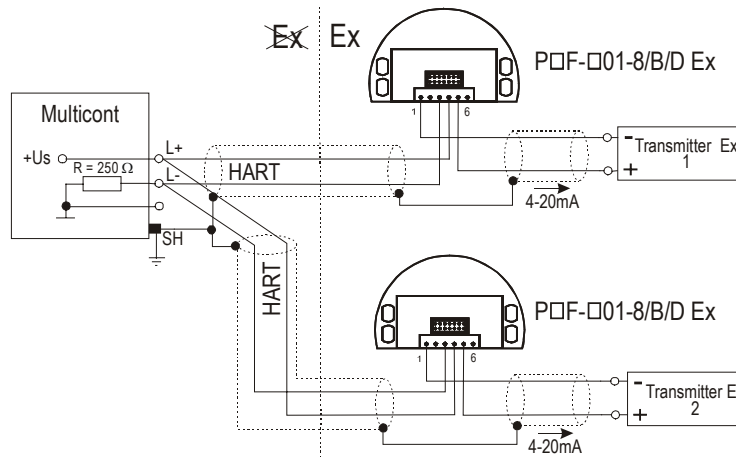

Figure 5. Wiring of 3-wire Uniconts with Multicont controller and 2-wire transmitters

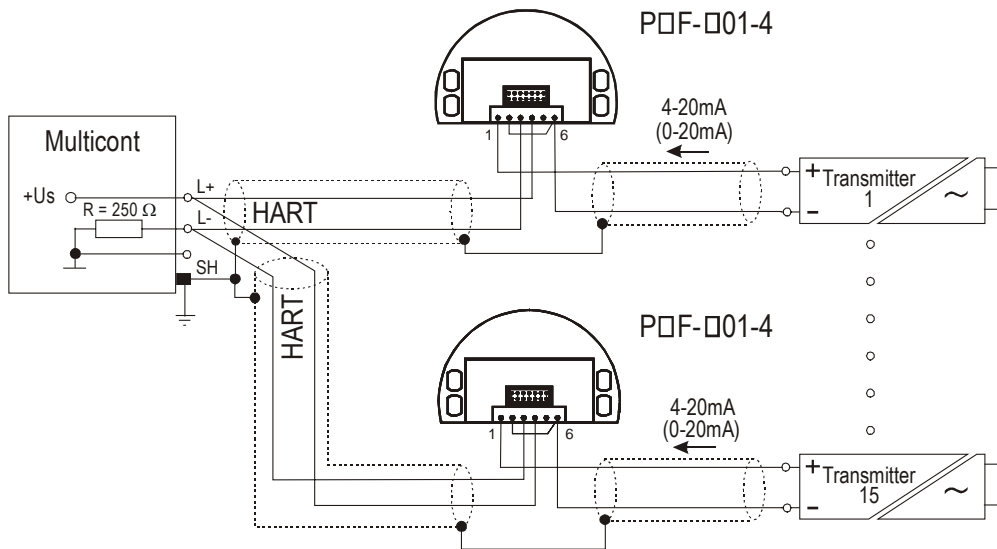

Figure 6. Wiring of 3-wire Uniconts with Multicont controller and 4-wire transmitters

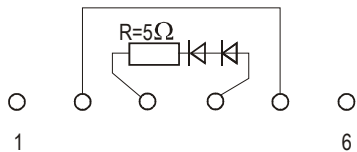

Figure 7. Internal wiring of the 2-wire Unicont

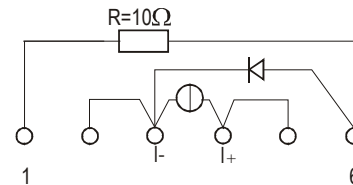

Figure 8. Internal wiring of the 3-wire Unicont

4.2 SAFETY REGULATIONS FOR THE EEx CERTIFIED UNITS

Intrinsically safe units with EEx ia IIC, EEx ia IIB or EEx d ia IIB markings can only be used in duly certified intrinsically safe loops with the previously given technical data.

Devices should be grounded by connecting their grounding screws to the equipotential system.

5. PUTTING INTO OPERATION, PROGRAMMING

Lighting of the VALID LED indicates that the Unicont, installed and wired correctly, will operate according to the Manufacturer's settings (see 5.1. Default).

The device operates in MEASUREMENT mode. It is indicated by the format of the displayed value and that the PROG display is not lit.

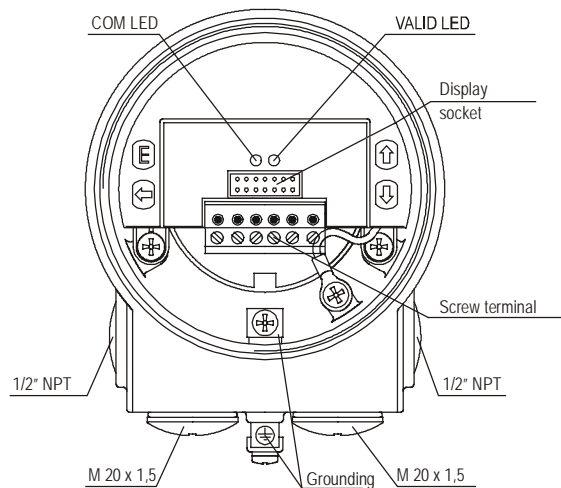

5.1 DEFAULT

Manufacturer's settings are the following:

The percental (%) value shown on the display is proportional to the input (4 mA→0%, 20 mA →100.0%).

Damping: 3 s

Noise suppression frequency: 50 Hz

Bargraph indication is proportional to the input (0/4 mA→0%, 20 mA →100.0%).

The output of the 3-wire models can be 4...20 mA current and / or HART signal

During operation:

COM LED flashes during HART communication

While pressing the \oplus key the input current appears on the display of the 2-wire models.

While pressing the \ominus key the output current appears on the display of the 3-wire models.

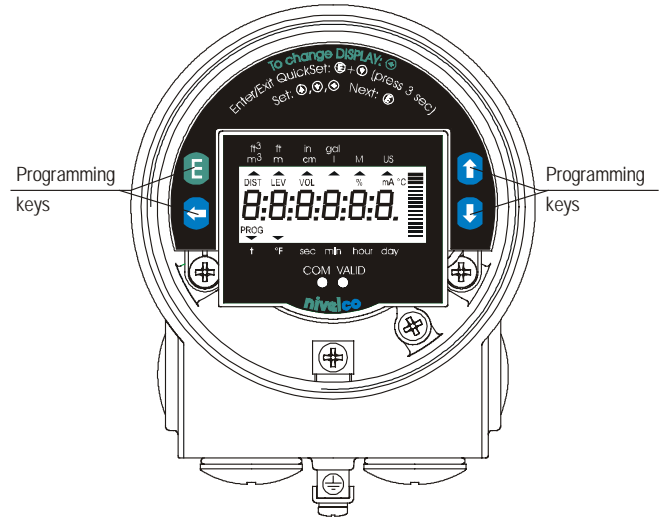

5.2 DISPLAY OF THE SAP-202 AND KEYS OF THE UNIT

Symbols on the screen

- DIST – distance displayed (when ON)
- LEV – level displayed (when ON)
- VOL – volume/content displayed (when ON)
- % – percent displayed (when ON)
- mA and °C current and temperature displayed (when ON)
- ▼ – arrow (points to the relevant engineering unit)
- PROG – programming is in progress (when flashing)



Symbols and sign on the frame

- M – metric system
- US – imperial engineering unit system
°F, m, cm, in, ft, l, m³, gal, ft³

LED

VALID lights up during operation

COM flashes during HART communication

5.3 PROGRAMMING

Uniconts can be programmed by programming keys and the procedure can be followed on the display. HART capable models can also be programmed remotely via the MultiCONT controller or with the aid of a HART modem and EView software installed on a PC. During on site programming remote programming is not possible and vice versa.

Adjustment of the Unicont to the conditions of the actual application can be carried out by programming the parameters. If the unit has already been programmed it is going to work according to the last setting.

The unit will work during programming in accordance with the parameters set previously.

The new, modified parameters will only be effective after returning to Measurement Mode.

If the transmitter is left in Programming Mode by mistake, it automatically returns to Measurement Mode after 3 minutes and is going to operate with the parameters entered during the last completed programming cycle.

5.3.1. STEPS OF PROGRAMMING

'Double key pressing' (pressing two keys simultaneously) has to be used to get into and out of PROGRAMMING mode. It is also used in programming mode. This is represented in the manual with the symbols of the two keys and the '+' sign in between them. That is: $\text{E} + \text{A}$ (getting into PROGRAMMING mode). This procedure should be carried out as follows: press the first key (E) and keep it pressed while pressing the key shown after the '+' sign (A). The two keys should be kept pressed simultaneously for about 3s (until the display changes).

After double key pressing of $\text{E} + \text{A}$ the device gets into PROGRAMMING mode and 'PROG' symbol is blinking. One of the following two images appears and parameters can be changed.

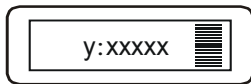

y one digit parameter address (0, 1, ... 9)
xxxxx five characters after the colon ":"



Bargraph

	X	X	X	X	X
possible	-	0	0	0	0
indications	1	:	:	:	:
in place of X	2	:	:	:	:
(- dark)	-	9	9	9	9

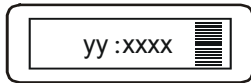

yy two digit parameter address (10, 11, ... 19)
dcba four characters after the colon ":" (during programming parameter value "a" blinks first!)



Bargraph

When 'PROG' is blinking programming can be performed. Since modification of P10 makes the unit restart and reset DEFAULT values it is suggested to begin programming with checking and / or changing this parameter.

When 'PROG' is lit, parameters are being protected by secret code and can only be read out. Applying this code (See P19) provides protection against unauthorised or unintended parameter modifications.

OPERATION OF THE PROGRAMMING KEYS

PRESSING KEY(S)	OPERATION	
Ⓔ + ⬅ * (press for minimum 3 sec)	Getting in and out of PROGRAMMING and MEASUREMENT mode (both directions). (Returning to Measurement mode means saving of the modifications)	
⬆ or ⬇	In MEASUREMENT mode input or output current appears on the screen of the 2-wire or 3-wire model respectively	
	while Parameter address blinking	while Parameter value blinking
Ⓔ	to select parameter address and go to parameter value	to save parameter value and return to parameter address
⬅ + ⬆	Cancel all modifications of the actual programming procedure. CANCEL will be displayed for warning.	Neglect value modification of the relevant parameter (if any) and return to the parameter address. CANCEL will be displayed
⬅ + ⬇	Reset all parameter values to default. LOAD is be displayed for warning	Reset default value of the relevant parameter. LOAD will be displayed for warning
⬆ + ⬇		GET VALUE – function for automatic setting of P0 and P1. Actual/measured value will be offered as the value to be programmed. After pressing Ⓔ for saving the value, 'SET' message confirms the modification.
⬅	To have the next character to the left blinking (to be able to change that character)	
⬆ / ⬇	Modify the blinking digit (increase, decrease, minus sign) or scroll up/down ... 8, 9, “-“, 0, 1, 2, ...	

Make sure that Ⓔ is pressed first!

Remarks:

Double key pressing is indicated by '+'

If, after pressing Ⓔ, blinking does not jump over from the parameter address to the parameter value, then this means that

- *the parameter is either read-out type, or*
- *the secret code prevents the modification (see P19)*

If the modification of the parameter value is not accepted i.e. the parameter value keeps blinking after pressing ENTER Ⓔ

- *the modified value is either out of range, or*
- *the entered code is not valid*

5.3.2. PARAMETERS – DESCRIPTION AND PROGRAMMING

Attention! Before programming it is suggested to read the description of parameter P10 carefully!

P0: - - - a Setting input current (Ia) that is to be assigned to displayed value (Da) See Figure 9, 10 and 11 **FACTORY DEFAULT: 4 mA**

P1: - - - a Setting input current (Ib) to be assigned to displayed value (Db) **FACTORY DEFAULT: 20 mA**

The current value can be entered in P0 and P1 manually

For instance, entering 5.6 mA in P0 should be performed as shown below:

1. Press E + \leftarrow to get into PROGRAMMING mode
2. Press \downarrow \uparrow to go to P0
3. Press E to go to the parameter value
4. Press \downarrow / \uparrow / \leftarrow to adjust the display to 5.6
5. Press E + \leftarrow to return to MEASUREMENT mode

If the actual current value is to be entered in P0 or P1 it can automatically be set by the GET VALUE function. To do so the above described procedure should be performed, but pressing \downarrow + \uparrow (instead of \downarrow / \uparrow / \leftarrow) (step 4.). Successful setting is indicated by the message 'SET' displayed.

Remarks:

If the input current range is set for 4 ... 20 mA, than the value of P11 can not be set below 4 mA in P0 and the value of P1 can not exceed 20 mA. An input current value outside of this range would make VALID LED and current value display blinking.

P2: Setting displayed value (Da) to be assigned to input current Ia See Figure 9, 10 and 11 **FACTORY DEFAULT: 0.0**

P3: Setting displayed value (Db) to be assigned to input current Ib **FACTORY DEFAULT: 100.0**

P4: Setting output current pertaining to the input current Ia (for 3-wire models only) **FACTORY DEFAULT: 4 mA**

P5: Setting output current pertaining to the input current Ib (for 3-wire models only) **FACTORY DEFAULT: 20 mA**

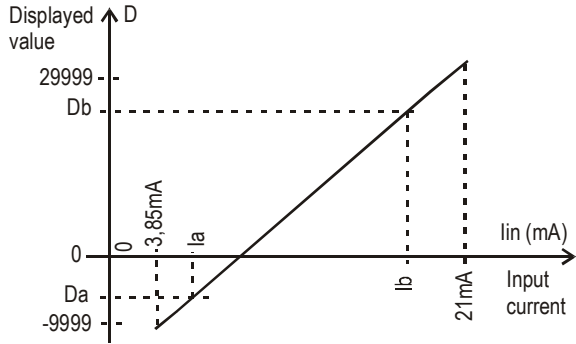

Figure 9. Display curve of 2-wire models

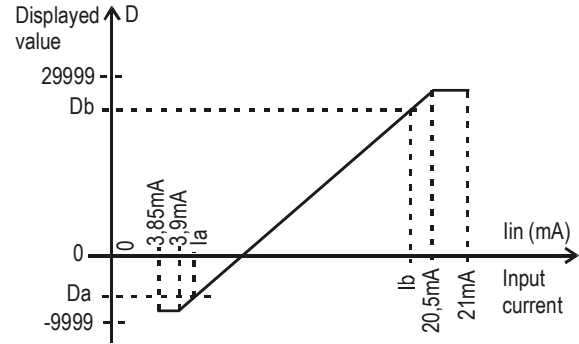

Figure 10. Display curve of 3-wire models with input range set for 4...20 mA

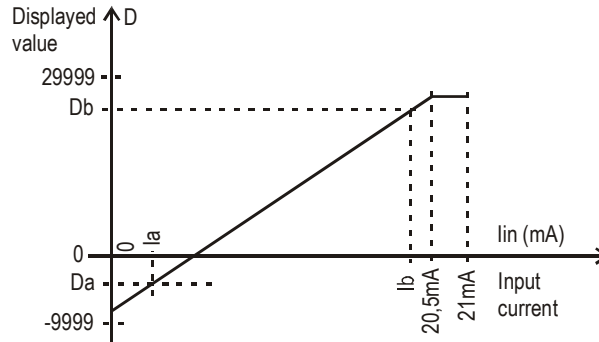

Figure 11. Display curve of 3-wire models with input range set for 0...20 mA

P9: --- a Current generator test**(for 3-wire models only)**

In this parameter the actual current output is displayed. Going to the parameter value the output current of 3.6...22 mA can be set by the keys \downarrow and \uparrow . The current value entered this way should conform with the output current measured with an ammeter.

P10: --- a Setting the decimal point**FACTORY DEFAULT: 0002**

Important remark: modification of P10 represents resetting parameter values to the FACTORY DEFAULT. Thus, it is suggested that programming starts with knowing the range of values to be displayed and programming P10 first.

a	Position of decimal point
0	xx.xxx
1	xxx.xx
2	xxxx.x
3	xxxxx

- a Range can be selected with the 3-wire models for 4...20 mA or 0...20 mA . Setting is important in respect to the output current error indication.
- b Damping can be used to reduce unwanted fluctuation of the displayed value
- c Noise suppression is for eliminating possible disturbance coming from the mains
- d Error indication on the current output of the 3-wire models is used to indicate error signals arriving as input current and the error of the Unicont itself according the chart below. Simultaneous occurrence of both errors is going to result output current to be the error indication of the Unicont.

* For 3-wire models only

Attention: character „a” is at the right end (this is the first to blink)

a	Range selection
0	4...20mA
1	0...20mA

b	Damping
0	3 s
1	5 s
2	10 s
3	20 s

c	Noise suppression
0	50 Hz
1	60 Hz

d	Error indication on the current output		
	Unicont error	Error indication on the input current*	
			Current > 20 mA
0	3.8 mA	3.8 mA	3.8 mA
1			22 mA
2		22 mA	3.8 mA
3	22 mA		
4	22 mA	3.8 mA	3.8 mA
5			22 mA
6		22 mA	3.8 mA
7			22 mA

*- If an error indication of 22 mA arrives (from a transmitter) to the input of the Unicont, with settings 5 (under d) than it means that the current output of the Unicont is 3.8 mA (and with setting 6 it is 22 mA)

- If an error indication of 3.8 mA arrives (from a transmitter) to the input of the Unicont, with settings 1 (under d) than it means that the current output of the Unicont is 22 mA (and with setting 6 it is 3.8 mA)

P12: dcba Displayed process values and their units**FACTORY DEFAULT: 0100**

The columns of the chart below can be programmed separately and it is supposed to be done reasonably (i.e. to have symbol LEV lit: 2 should be set under b, to have relevant unit lit (m/ft or cm/in) 2 or 3 should be set under a and setting 1 under d should be chosen if the required unit is meter or centimetre. This also means that there is no engineering unit to set for FLOW (it can be displayed in %)

Settings in column 'a' make engineering units lit on the frame (c should be set to 0)

Settings in column 'b' make the symbols (DIST, LEV, VOL, FLOW) lit on the frame

Settings in column 'c' make %, mA or °C lit on the frame (a should be set 0)

	a	b	c	d
1	m ³ /ft ³	DIST	%	M
2	m/ft	LEV	mA	US
3	cm/in	VOL	°C	-
4	l/gal	FLOW	-	-
5	t	-	-	-
6	°F	-	-	-

P13: 00ba HART short address (for 3-wire models only)**FACTORY DEFAULT: 00**

The short address of the unit for the multidrop system (HART network) is to be given here.

Please note that in accordance with the HART standards the address of a single device should be 00. In this case current output will change according to the settings in the range of 3.8 ... 22 mA and HART communication is also available.

For systems with more than one device 01 ...15 addresses should be given. In these cases the output current will be fixed to 4 mA. Thus, information is transferred by the HART communication only (i.e. current output does not carry any information and error indication on the current output is not possible). (See also 'Description of Eview' supplied with HART capable devices.)

P14: dcba Product version

Hardware and software versions of the model can be found in this parameter.

d = 0 not HART capable d = 1 HART capable c = hardware version, ba = software version

Engineering units transferred by HART communication can be set in this parameter.

CODE	DIMENSION	CODE	DIMENSION	CODE	DIMENSION	CODE	DIMENSION	CODE	DIMENSION	CODE	DIMENSION
0	-	26	ft ³ /s	52	h	78	MetTon/h	114	in/s	143	deg
1	inH20@68°F	27	ft ³ /d	53	d	79	MetTon/d	115	in/min	144	rad
2	inHg@0°C	28	m ³ /s	54		80	lb/s	116	ft/min	145	inH20@60°F
3	ftH20@68°F	29	m ³ /d	55		81	lb/min	117	deg/s	146	
4	mmH20@68°F	30	Impgal/h	56	uS	82	lb/d	118	rev/s	147	
5	mmHg@0°C	31	Impgal/d	57	%	83	lb/d	119	rev/m	148	
6	psi	32	°C	58	V	84	STon/min	120	m/h	149	Vol
7	bar	33	°F	59	pH	85	STon/h	124	bbl liq	150	
8	mbar	34	°R	60	g	86	STon/d	125	ounce	151	
9	g/cm ²	35	Kelvin	61	kg	87	LTon/h	126		152	ft ³ /lb
10	kg/cm ²	36	mV	62	MetTon	88	LTon/d	127	kW	153	pF
11	Pa	37	ohm	63	lb	89		128	kWh	154	mL/L
12	kPa	38	Hz	64	STon	90		129	hp	155	uL/L
13	torr	39	mA	65	LTon	91	g/cm ³	130	ft ³ /h	163	kohm
14	atm	40	gal	66	mS/cm	92	kg/cm ³	131	m ³ /min	164	MJ
15	Ft ³	41	L	67	uS/cm	93	lb/gal	132	bbl/s	235	gal/d
16	min	42	Impgal	68	N	94	lb/ft ³	133	bbl/min	237	Mpa
17	L/min	43	m ³	69		95	g/mL	134	bbl/h	238	inH20@4°C
18	Impgal/min	44	ft	70	g/s	96	kg/L	135	bbl/d	239	mmH20@4°C
19	M ³ /h	45	m	71	g/min	97	g/L	136	gal/h	240	L/d
20	ft/s	46	bbl	72	g/h	98	lb/in ³	137	Impgal/s	241	kg/dm ³
21	m/s	47	in	73	kg/s	99	STon/yd ³	138	L/h	242	ms
22	gal/s	48	cm	74	kg/min	100	yd ³	139	ppm	243	ft/h
23	Mgal/d	49	mm	75	kg/h	111	ft ³	140		244	dB
24	L/s	50	min	76	kg/d	112	in ³	141	HJ/h	245	m/s ²
25	ML/d	51	s	77	MetTon/min	113	in/s	142		246	ft/s ²

Codes over 240 are engineering units defined by NIVELCO They might be different at other manufacturers.

P19: Secret code

FACTORY DEFAULT: 0000

Settings can be protected by a 4 digit number (secret code) (other than 0000) entered in this parameter. If the secret code is active the PROG symbol is lit and the value of the parameters can only be viewed.

To be able to do any programming or to modify the secret code or to remove protection (modify the secret code to 0000) the secret code, already entered, needs to be known. The procedure is the following: Go to P19 press E to select parameter address. Then go to parameter value, enter the secret code. Press E to go to the address and E again to return to value. Enter the new secret code or 0000.

If there is no secret code or it is not active the PROG symbol is blinking

5.4 ERROR INDICATIONS

5.4.1. VALID LED IS BLINKING AND A MESSAGE OF ERRX APPEARS ON THE DISPLAY

ERR (X)	Error description	Causes and solution
1	Memory error	Contact local agent
2	Programming error: same value in P0 and P1 or in P2 and P3 or same value in P4 and P5 with the 3-wire models	Modify programming
3	Display overflow	— ” —

5.4.2. VALID LED AND THE DISPLAYED VALUE IS BLINKING

For the 4...20 mA range: if $\text{lin} < 3.85 \text{ mA}$ or $\text{lin} > 21 \text{ mA}$

For the 0...20 mA range: if $\text{lin} > 21 \text{ mA}$

5.4.3. ERROR INDICATION ON THE OUTPUT CURRENT (FOR 3-WIRE MODELS ONLY)

Output current is 3.8 mA or 22 mA, depending on setting of character d in P11

6. MAINTENANCE AND REPAIR

The unit does not require regular maintenance. In case of need the unit might be carefully cleaned. All repairs will be carried out only on the premises of the Manufacturer.

7. STORAGE

Ambient temperature: -25 °C ... +60 °C

Relative humidity: max. 98 %

pdf4012a0600p_03.doc
NIVELCO Process Control Co.
May 2006.

NIVELCO reserves the right to change technical specifications without notice.